

***SOLARONICS, INC.***  
**'DJTE' GAS-FIRED MODULATING**  
**DOORJET HEATER**

**INSTALLATION, OPERATION, AND MAINTENANCE  
INSTRUCTIONS (HONEYWELL VERSION)**

**NOT FOR RESIDENTIAL USE**

**FOR YOUR SAFETY**  
**IF YOU SMELL GAS:**

1. Open windows.
2. Don't touch electrical switches.
3. Extinguish any open flames.
4. Evacuate the structure.
5. Immediately call your gas supplier.

**!! WARNING !!**

Read and understand **ALL** instructions **BEFORE** attempting to install, operate, or service this heater. Failure to follow the installation, operation, and maintenance instructions or any substitution of factory installed parts without prior written permission of **Solaronics, Inc.** will void all warranties. Failure to comply with this procedure may result in unsafe operation, property damage, personal injury and or death.

**FOR YOUR SAFETY**

The use and storage of gasoline or other flammable vapors and liquids in open containers in the vicinity of this heater is hazardous.

FOR TOLL FREE TECHNICAL SUPPORT, CALL 1-800-223-5335  
3720 LAPEER ROAD, AUBURN HILLS MICHIGAN 48326 USA

# FOREWARD

This instruction manual may not cover all details or variations in this equipment or cover every possible situation to be met in connection with installation, operation or maintenance. Should problems arise that are not covered sufficiently in these instructions, the purchaser is to contact the manufacturer.

Additional copies of this manual may be ordered from the manufacturer by using the serial number on the nameplate of the equipment. Furnish the name and address of the person requesting the material. Billing is according to current prices.

Carefully read and understand all instructions BEFORE attempting to install, operate or service this equipment. It is the installing contractors' responsibility to confirm by actual testing this equipment is installed within the manufacturers' design parameters as indicated on the heaters' serial rating plate.

Failure to follow installation, operation and maintenance instructions or any substitution of factory installed parts without the written permission of the manufacturer will VOID all warranties. Failure to comply with this procedure may result in unsafe operation, personal injury, fire, asphyxiation and/or death.

# **SAFETY ACCESSORIES, APPLICATION, AND USE**

## **WARNING**

- **INSTALLER**
- **USER**
- **OWNER**
- **EMPLOYER**

The safe application and use of this equipment is **your** responsibility. The application and use of this equipment can vary greatly. For most applications and use, diversified product models and optional safety accessories are available. This equipment may be sold with or without safety accessories. The diversity of applications for this heater precludes the manufacturer from establishing or warranting the efficacy of safe operating conditions which may result from its' use. The installer, user, owner, employer must determine the specific safety requirements. The specific safety requirements will vary depending on the location and operating procedures. Therefore, appropriate safety accessories can only be supplied upon the receipt of an order.

The need for safety accessories will many times depend on the following:

- Type of system (*tempering air at door entry, drying, etc.*)
- Heater location
- Operating procedures
- Environmental conditions
- Company standards
- Local codes
- OSHA requirements
- Recirculating air
- Electrical interlocks
- Human interaction

The installer, user, owner, employer is advised to specify and obtain the required safety accessories from the manufacturer. **DO NOT ALLOW THE EQUIPMENT TO BE OPERATED WITHOUT THEM! PROPERTY DAMAGE, PERSONAL INJURY, OR DEATH CAN OCCUR!**

Before using, read and understand "RECOMMENDED SAFETY PRACTICES FOR USERS AND INSTALLERS OF INDUSTRIAL AND COMMERCIAL FANS". It is a publication of the Air Movement Control Association, Inc., 30 West University Drive, Arlington Heights, Illinois 60004. A copy is attached to each heater.

**HAZARD INTENSITY LEVELS**

- 1. DANGER:** Failure to comply will result in severe personal injury or death and/or property damage.
- 2. WARNING:** Failure to comply could result in severe personal injury or death and/or property damage.
- 3. CAUTION:** Failure to comply could result in minor personal injury and/or property damage.

**Page 1**

**GAS-FIRED MODULATING DOOR HEATER INSTRUCTIONS**

APPLIES TO: Installation \* Operation \* Maintenance

This instruction manual may not cover all details or variations in this equipment, or cover every possible situation to be met in connection with installation, operation, or maintenance. Should problems arise that are not covered sufficiently in these instructions, the purchaser is advised to contact the manufacturer.

Additional copies of this manual may be ordered by using the serial number on the nameplate of the equipment. Furnish the name and address of the person requesting the manual. Billing is according to prices in effect at the time of the order.

**!! WARNING !!**

Gas-fired heaters are not designed for use in hazardous atmospheres containing flammable vapors or combustible dust, or atmospheres containing chlorinated or halogenated hydrocarbons. See Hazard Intensity Levels, page 1.

**NOT FOR RESIDENTIAL USE**

**1.00 GENERAL INFORMATION AND INSTALLATION CODES**

**!! CAUTION !!**

Contact your local building department or the gas company for installation approval requirements. They will specify this equipment be installed in accordance with various national and/or local codes, regulations, or ordinances. In particular, the installation should conform to:

- ANSI Z223.1/NFPA 54 (latest edition) – National Fuel Gas Code
- ANSI/NFPA 70 (latest edition) National Electrical Code
- Occupational Safety and Health Act (OSHA) approved service and safety access to the heater.
- NFPA 409 or 30 may apply to certain installations.

**TABLE OF CONTENTS**

<u>Section</u>	<u>Description</u>	<u>Page</u>
1.00	General Info/Installation Codes.....	1
2.00	Receiving/Inspection/Handling.....	2
3.00	Description of Equipment.....	2
4.00	Notes to Installing Contractor.....	2,3
5.00	Gas Pressure Regulator Info.....	4
6.00	Installation – Gas Piping.....	4,5
7.00	Installation – Electrical.....	5
8.00	Door Interlock Switch.....	5
9.00	Safety Equipment.....	6
10.00	Maintenance.....	6
11.00	Initial Start-Up.....	7
12.00	Sequence of Operation.....	7,8
13.00	Troubleshooting.....	8
14.00	Replacement Parts.....	9
15.00	Additional Drawings, Figures 1-6, and Manufacturer Component Sheets.....	

**THIS HEATER IS DESIGNED TO OPERATE WITH AND MUST BE WIRED TO A DOOR INTERLOCK SWITCH ONLY PER THE MANUFACTURERS' INSTRUCTIONS.**

This heater must only be installed, operated, and serviced by qualified, trained, licensed gas installation and service personnel familiar with all requirements.

Permits from local authorities covering installation, gas plumbing, and electrical are usually required. Gas company approvals are usually required.

Copyright © 2024

All rights reserved. No part of this work covered herein may be reproduced or copied by any means – graphic, electronic or mechanical, including photocopying, taping or information storage and retrieval systems – without written permission.

## 2.00 RECEIVING / INSPECTION / HANDLING

All units are test-fired and inspected in our plant before being accepted by the carrier. The quantity of packages and contents are listed on the bill of lading and packing list. Units should be carefully inspected upon arrival. If there are any damages or shortages, note them on the receiving papers at the time of delivery. Claims must be filed with the carrier within five (5) days. The various conditions under which units are shipped, unloaded, and installed make it impossible for the manufacturer to accept responsibility of handling in transit.

Units can be handled with a fork lift truck. Remove shipping skids and/or crating when unit is on location.

## 3.00 DESCRIPTION

The gas-fired modulating door heater's purpose is to temper air at the door opening area when the door is opened directly to the out-of-doors. Air to the heater may be taken from the building, ONLY when the door is open, ducted directly from outdoors or a combination of both, and the products of combustion generated by the heater are released into the air stream heated.

### **IT IS NOT A SPACE HEATER!**

NEVER use a space heating thermostat to turn this unit ON and OFF.

### **IT IS NOT AN AIR MAKE-UP UNIT!**

In a building with a severe pressure condition, due to a lack of make-up air, the door heaters' efficiency may be seriously impaired. The burner is designed to operate on natural gas. The fan propeller is specially designed and directly connected to an industrial duty totally enclosed fan cooled motor.

**THIS HEATER IS DESIGNED TO OPERATE WITH AND MUST BE WIRED TO A DOOR INTERLOCK SWITCH ONLY PER THE MANUFACTURERS' INSTRUCTIONS AS DISCUSSED ELSEWHERE IN THIS MANUAL.**

If there are any doubts or questions regarding the application of this heater, call the manufacturer **BEFORE** attempting installation.

## Page 2

### **GAS-FIRED MODULATING DOOR HEATER INSTRUCTIONS**

APPLIES TO: Installation \* Operation \* Maintenance

### **!! CAUTION !!**

**Recirculation of room air may be hazardous in the presence of:**

- **Flammable solids, liquids, and gasses**
- **Explosive material (i.e. grain dust, coal dust, gunpowder, etc.)**
- **Substances, which may become toxic when, exposed to heat (i.e. refrigerants, aerosols, etc.)**

The products of combustion are discharged directly into the air stream and consist mainly of water vapor and carbon dioxide. CO and CO<sub>2</sub> concentrations are well below the maximum allowable by the American Conference of Governmental Industrial Hygienists. At maximum rated heat output, the relative humidity of the discharge air is less than that of the incoming air. In most cases, it is less than 5% relative humidity.

## 4.00 NOTES TO INSTALLING CONTRACTOR

A general rule-of-thumb to determine size (BTUH rating) and number of heaters for the door opening is on the basis of approximately 5,500 BTUH per square foot of door opening. One door heater will handle door openings up to about 12 foot by 12 foot. Larger openings require two or more door heaters.

The standard door heater is arranged to be mounted in any position from vertical down to a horizontal position (see Figures 1 and 6). Controls are located on the right hand side when facing into the air stream (unless the left hand option has been ordered).

**!! WARNING !!**

SEE FIGURE 6. The manual reset high temperature limit **MUST ALWAYS** be to the top of the heater. It is located inside of the 2" x 4" wiring junction box which is located on top of the heater shell. Whichever side the control cabinet is on, it must always be facing the ceiling for any angle between horizontal and vertical. This minimizes water from entering the wiring junction box and affecting the electrical operation.

**!! CAUTION !!**

Be certain there are no obstructions within 24" of the inlet, and no obstructions at the outlet. Be certain there is no combustible material within 36" of the sides of the unit. Most insurance requirements specify an open flame device such as a door heater may be no closer than 20 feet from spray booths, dip tanks, or other sources of flammable vapors.

Again, no door heater can substitute for an air make-up system. If severe building negative pressure exists because of exhaust load, make-up air must be provided before a door heater will operate properly.

Door heaters must be installed in accordance with applicable codes. In the absence of local codes, installation must be in accordance with the latest edition of the NATIONAL FUEL GAS CODE ANSI Z223.1 and its' addendums.

All electrical work, specifically, an electrical disconnect switch having adequate ampacity (Article 430) and the electrical grounding, must conform to the latest edition of the NATIONAL ELECTRICAL CODE ANSI/NFPA 70 and its' addendums.

The installation must meet the requirements of the Occupational Safety and Health Act (OSHA).

**THE INSTALLING CONTRACTOR, OR PERSON, MUST BE FAMILIAR WITH ALL OF THE VARIOUS REQUIREMENTS AND IS RESPONSIBLE FOR THE HEATERS' COMPLIANCE WITH ALL THE APPLICABLE CODES, REGULATIONS, AND ORDINANCES.**

**Page 3**

**GAS-FIRED MODULATING DOOR HEATER INSTRUCTIONS**

APPLIES TO: Installation \* Operation \* Maintenance

The diversity of field installations possible for this heater precludes a definitive installation procedure. When designing an installation, keep in mind the following:

- Refer to Figures 1 and 6 in this manual for proper orientation and typical applications of this heater.
- Maintain clearances as noted in the CAUTION box on page 3.
- The heater weighs around 300 pounds and must be rigidly and securely hung in its final position. Damage to the heater will result unless adequate support is provided. See Figure 4 for suggested materials.
- Noise and vibration transfer to the building can be reduced with the use of vibration isolators and, where allowed, flexible gas, electrical, and duct connections.
- All equipment, which has gas and electrical supplies connected to it, should be treated with the greatest respect at all times to avoid any chance of accident.
- A 1" NPT manual safety shutoff gas cock 'A' and a 1/8" NPT supply pressure test tap upstream of the heaters' gas inlet must be furnished and installed by the purchaser.

Check nuts, bolts, setscrews, etc., on the heater for tightness since some may have been loosened in transit. Specifically check the following:

- Motor mounts
- Burner mounts
- Propeller (rotate by hand to make certain no rubbing occurs)
- Pipe unions and mounting for tightness
- Terminal strip wire connections for tightness
- Air flow switch mounting for tightness

## 5.00 GAS PRESSURE REGULATOR INFORMATION

The gas pressure regulator 'REG' supplied with this heater is designed to operate properly over a 7" to 14" w.c. range of inlet gas supply pressure. (NOTE: 8" w.c. to 14" w.c. for models' at 850,000 and 950,000 BTUH). If the supply pressure can go above 14" w.c. (1/2 p.s.i.) at any time, a separate appropriately sized lockup service regulator must be installed upstream of the heaters' integral regulator.

Check with the data sheet in the front of this manual as well as the rating plate for the model number, BTUH input, inlet and manifold gas pressures, and voltage.

Check that the regulator is installed correctly with the arrow on the body pointing in the direction of gas flow.

The gas regulator 'REG' and modulator valve 'CV' have a vent line running to the control cabinet wall assuring gas is vented outside of the cabinet. Remove shipping tape. Check local codes. When venting the regulator and modulator valve out-of-doors, use a pipe at least one size larger than the vent tapping. Provide the shortest run possible with as few bends as possible. Avoid sharp bends if tubing is used. The outside of the vent line termination should have a screened weatherproof vent cap and should point down. Locate in area safe to release gas. Restricted or clogged vent lines will cause poor regulator performance.

Although the regulator is factory set, field adjustments may be necessary. Remove top cap of regulator. Screwing the regulator adjustment screw "in" will raise its outlet pressure. Screwing "out" will lower the pressure. Always check the manifold pressure under flow conditions with the heater in operation. Make all measurements at the pressure test tap provided adjacent to the 1" NPT pipe union (located in cabinet) **when the heater is on High Fire.**

### Checking/Setting Manifold Pressure

To check continuous High Fire: shut-off electrical power to heater, and disconnect wire from amplifier terminal 4 (see page 4, A1014R Model Amplifier.) This causes the valve to call for continuous high fire. Safely isolate disconnected wire during pressure check. Restore electrical power to heater when ready to test.

Following are approximate burner **High Fire** manifold gas pressure settings (natural gas):

- 2.25" w.c. – 550,000 BTUH
- 3.00" w.c. – 650,000 BTUH
- 3.75" w.c. – 750,000 BTUH
- 4.75" w.c. – 850,000 BTUH
- 6.00" w.c. – 950,000 BTUH

## Page 4

### GAS-FIRED MODULATING DOOR HEATER INSTRUCTIONS

APPLIES TO: Installation \* Operation \* Maintenance

When manifold pressure checking/setting is complete, shut off electrical power to heater and reattach wire to amplifier terminal 4.

## 6.00 INSTALLATION GAS PIPING

**NOTE:** Gas pressure must be measured with a water or red oil manometer – NOT A DIAL GAUGE. All measurements must be made when this heater and all other gas burning equipment connected to the same gas meter are operating at maximum operating capacity. It should be assured, by an actual test, the burner manifold gas pressure at the burner inlet is not greater than the value given on page 4 and double-check it against the heaters' rating plate.

Gas piping is to be sized and installed in accordance with all applicable local and national codes. Check the installation site gas supply pressure and capacity to be certain they agree. Incoming gas piping to the heater must be independently supported.

A drip leg and ground joint union **MUST** be provided in the gas supply line to the heater. Before connecting gas service, all pipe should be thoroughly cleaned and leak tested in accordance with all local codes. Check all gas lines with a soap solution ---

### **NEVER USE A FLAME!**

Pipe joint compound, resistant to LP/propane gas action, **MUST** always be used at all pipe connections.

Vent valve, if provided, is to be vented outdoors (by others). Other gas pressure regulators and gas pressure switches, if provided, are to be vented outdoors or provided with approved vent limiting devices. Termination of vent lines outdoors are to be provided with a means (by others) to prevent stoppage by foreign material, moisture, or insects.

Purge all gas lines BEFORE attempting to light-off the burner.

## 6.00 INSTALLATION

### GAS PIPING (CONTINUED)

The heater and its' individual manual gas shutoff cock 'A' (by others) must be disconnected/100% shut off from the gas supply piping system during any high pressure testing of that system at test pressures above 14" w.c. (1/2 p.s.i.). The heater must be isolated from the gas supply piping system by closing its' individual manual shutoff gas cock 'A' (by others) during any pressure testing of the gas supply piping system at test pressures equal to or less than 14" w.c. (1/2 p.s.i.).

#### **!! WARNING !!**

**ALL components of a gas supply system must be leak tested prior to placing equipment into service. NEVER test for leaks with an open flame. See Hazard Levels, page 1.**

## 7.00 INSTALLATION

### ELECTRICAL

All wiring must conform to the latest edition of the NATIONAL ELECTRICAL CODE or to the local code legally authorized. This heater **MUST** be electrically grounded, in accordance with the latest edition of the NATIONAL ELECTRICAL CODE.

Electrical power take-off must be connected to a separate, fused circuit and provided with a disconnect means in accordance with the NATIONAL ELECTRICAL CODE.

Check the data/cover sheet in the front of this manual and the heaters' rating plate for comparing to the buildings' power supply.

An electrical diagram, located on the backside of the top electrical cabinet door, is provided for convenience in servicing the heater. Install the door interlock switch as described in Section 8. Install the remote control operating cabinet at any convenient location. Refer to Figure 2.

## 8.00 DOOR INTERLOCK SWITCH

Experience has shown most interlock failures are the fault of the installation. In some cases, an installation that is not perfect cannot be avoided, but in the majority of cases, proper application of the interlock switch would have prevented failure.

## Page 5

### GAS-FIRED MODULATING DOOR HEATER INSTRUCTIONS

APPLIES TO: Installation \* Operation \* Maintenance

Interlock switches should be mounted in locations which will prevent accidental operation by normal movements of operator or some machine movement. They should be mounted rigidly and in easily accessible locations, with suitable clearances to permit easy service and replacement when necessary. Cover plates should face the maintenance access point.

Interlock switch leakage is often traced to the conduit system. Condensation in the conduit line can enter the switch through the conduit hole. Water tightness depends upon the condition of the conduit connection/seal.

To insure a water tight seal, make sure the conduit entry is at the bottom of the remote cabinet and, use thread sealant, a conduit seal or seal bushing with the conduit fitting.

Install the interlock switch on the door frame so it is tripped by the opening of the door. The switch has one normally open and one normally closed contact, so whichever pole is closed by the action of the door, it may be used to actuate the heater. Local codes may require the location of the switch at the top of the door opening so as to make it less accessible and less prone to mechanical damage.

For your consideration, when designing for your specific field conditions, refer to Figures 1 and 3 for typical door interlock switch application.

The single pole, double throw contacts in an interlock switch should not be used on opposite polarities. When one contact of a switch is connected to the L1 side of a load, and the other contact to the L2 side of the load, a line-to-line short can occur through the arc which may occur as the contacts operate. When contacts are connected to the same polarity, this line-to-line short cannot occur.

## 9.00 SAFETY EQUIPMENT

- MAIN GAS VALVE – Solenoid operated safety shutoff valve rated to 5 PSI maximum gas pressure. UL approved.
- HIGH TEMPERATURE LIMIT – located near the heater discharge ON TOP of the heater in a 2 x 4 wiring junction box. This control requires a manual reset when excessive temperature occurs.
- AIR FLOW SWITCH – Assures proper volume of air flow before burner can be ignited.
- FLAME SAFEGUARD/RELAY – Electronic solid state relay operates with an ultra-violet flame scanner to sense the presence of flame. Flame scanner helps to assure troublefree operation. Lockout occurs if flame is not sensed in 12 seconds. Shutdown on flame failure occurs within 0.8 seconds.
- MOTOR STARTER INTERLOCK – This is integral to the motor starter and is wired into the circuit to assure fan operation before burner ignition begins.
- TIME DELAY RELAY – This relay provides a (10) ten second post-purge running of the fan after the door interlock switch opens (door closes) or there is a loss of flame sensing lockout. It assures any residual gas is purged out of the system.
- GAS MODULATING SYSTEM – The basic Maxitrol system consists of: the solid state amplifier; remote temperature selector; discharge air sensor and mixing tube; and the modulator valve. The 24 VAC system features electronic temperature sensing – providing instantaneous response and extreme sensitivity. Read Maxitrol's Safety Warning Instructions in the component sheet section of this manual.

## 10.00 MAINTENANCE

**BEFORE** performing any maintenance, disconnect and lockout the electrical supply by positive means. All maintenance must be performed by qualified, trained service personnel.

**MONTHLY:** During heating season, check operation of safety controls:

- Flame Safeguard/Relay – 'FR'
- Air Flow Switch – 'AF-1'
- High Temperature Limit – 'HTL'
- Time Delay Relay – 'TDR'

## Page 6

### GAS-FIRED MODULATING DOOR HEATER INSTRUCTIONS

APPLIES TO: Installation \* Operation \* Maintenance

- Wipe lens of flame scanner 'FS' and check that viewing hole is not blocked
- Check that sensing points of air flow switch 'AF-1' are not blocked
- Check gas vent line from 'REG' and 'CV' is not blocked up to its (indoors or outdoors) termination
- Clean inlet air guard (if installed) of any dirt/dust buildup to assure clear passageways for combustion air
- Clean the propeller blades; a buildup of dirt and dust can cause an imbalance
- In car washes, wipe clean the ignition wire and spark plug 'SP'

**ANNUALLY:** At start of heating season:

- Check and clean burner, burner ports, and mixing plates
- Check gas manifold pressure (Refer to page 4 for proper setting)
- Replace spark plug 'SP', especially in car wash applications
- Check high voltage lead-in wire for deterioration
- Check and clean propeller blades
- Check motor mounting
- Check burner mounting
- Check heaters' support mounting
- Check piping and controls for gas leaks  
**NEVER USE A FLAME! – use a soap solution**
- Lubricate motor according to manufacturers' directions – if applicable

In accordance with some codes or under adverse conditions, such as a car wash, it may be necessary to inspect or service some items more often. The use of an inspection form is recommended. Preventative maintenance is the best way to get long and troublefree service from this heater.

## 11.00 INITIAL STARTUP AFTER INSTALLATION

All door heaters are assembled, wired, piped, and test-fired in our factory before shipment. The initial startup procedure at the job site is mainly a recheck and adjustment to field conditions which may vary somewhat from factory conditions.

Check that manual gas shutoff cock 'A' is closed and disconnect switch 'DS-1' is open. Check that selector switches 'SS-1' and 'SS-2' (both are in the remote control operating station) are in the "OFF" position – no lights are on.

Connect a test manometer to the incoming pressure test point (refer to page 3, second column) and to the burner manifold pressure test tap located inside the main cabinet.

Close the disconnect switch 'DS-1' and check that propeller is rotating clockwise, when heater is viewed facing air flow (SEE FIGURE 6), by placing 'SS-1' into the "ON" position (light comes on). If necessary, reverse any two power leads at the disconnect switch to reverse the propellers' direction.

Manually reset the following controls:

- Flame safeguard/relay 'FR' – located in the main control cabinet.
- If provided, high and low gas pressure switches – piped into gas train. Refer to piping schematic for location.
- High temperature limit 'HTL' – located on top of heater shell in a 2 x 4 wiring junction box (SEE FIGURE 6); remove cover for access.

Open main gas shutoff cock 'A' and test the incoming gas piping for leaks. Repair, if necessary. Place 'SS-2' in the "ON" position (light comes on). Adjust gas pressure regulator(s) if necessary (refer to page 4, first column) to never exceed 14" w.c. incoming pressure and proper burner manifold pressure to obtain correct output capacity required. Refer to Section 12; Sequence of Operation.

After removing manometers and reinstalling test plugs, leak test, with a soap solution, these test taps with burner running. The heater should be cycled several times by switch 'SS-1', allowing at least one (1)

## Page 7

### GAS-FIRED MODULATING DOOR HEATER INSTRUCTIONS

APPLIES TO: Installation \* Operation \* Maintenance

minute between cycles. To shut down, place 'SS-1' in the "OFF" position or open the disconnect switch 'DS-1'.

**NOTE:** In a car wash environment, where humidity is a problem, it may be necessary, at the initial startup of the morning, to place 'SS-2' in the "OFF" position allowing only the fan to run for approximately one (1) minute helping dry off the spark plug 'SP' and ignition wire before attempting to light-off the burner. This may also be necessary from time to time during the day if there are extreme humidity conditions.

## 12.00 SEQUENCE OF OPERATION

### SUMMER OPERATION:

1. If heater is not to run when door opens, place 'SS-1' in the "OFF" position.
2. If heater is to recirculate air with no heat, place 'SS-2' in the "OFF" position. Leaving 'SS-1' in the "ON" position, only the fan will operate in response to the door interlock switch 'DIS' action.

### WINTER OPERATION

1. Close disconnect switch 'DS-1' and open manual gas shutoff cock 'A'.
2. 'SS-1' and 'SS-2' must both be in the "ON" position (lights are on).
3. At the remote temperature selector 'RTS' (in remote control cabinet), set the desired operating temperature.
4. Opening the door will close the contact on the door interlock switch 'DIS' which energizes 'MU' motor starter coil through the 'TDR' closed contact and fan will start.
5. 'MU' motor starter contact will close.
6. Air flow switch 'AF-1' will close.
7. Flame safeguard/relay 'FR' will be energized to begin burner lightoff.
8. Ignition transformer 'TR-2' is energized producing spark at the spark plug 'SP'.
9. If high temperature limit 'HTL' is closed, main gas solenoid valve 'S-2' and the Maxitrol system are energized.

### **WINTER OPERATION (continued)**

10. If UV scanner 'FS' senses flame, heater will function normally.
11. Heater will now cycle off and on in response to the action of the door interlock switch 'DIS' and gas flow is modulated to the burner to maintain the desired temperature setting.
12. When door closes ('DIS' contact opens), burner shuts off and 'TDR' begins a (10) ten second post-purge time running of the fan. After it times out, heater completely shuts down.
13. 'TDR' automatically resets itself when door opens ('DIS' closes).

### **TO SHUT DOWN:**

1. Place 'SS-1' and 'SS-2' in the "OFF" position in the remote control cabinet.
2. For summer shut down, also open disconnect switch 'DS-1' and close manual shutoff gas cock 'A' to heater.

## **13.00 TROUBLESHOOTING**

### **(Ref. Dwg. No. C-141251)**

#### **FAN DOES NOT COME ON – STANDARD CONTROLS**

1. In disconnect switch 'DS-1', check fuses and be certain switch is closed.
2. Check fuse 'FU' in remote control operating station.
3. Be certain 'SS-1' switch/light is "ON".
4. Be certain 'SS-2' switch/light is "ON".
5. Be certain door interlock switch 'DIS' is making contact as door opens.
6. Check if 'TDR' is "ON".
7. Check overload relays 'OL' on 'MU' motor starter – push in reset button.

#### **FAN COMES ON/BURNER DOES NOT COME ON – STANDARD CONTROLS**

1. Be certain manual shutoff gas cock 'A' is open.
2. Check airflow switch 'AF-1' to be sure steady contact is made.
3. Reset flame relay 'FR' if tripped. If lockout persists, see service suggestions in manufacturers' flame relay bulletin included with this manual. *Note: In a car wash environment, lockout may occur due to water and/or chemicals being directly on the spark plug 'SP' and ignition wire. This can cause the spark to occur other than at*

## **GAS-FIRED MODULATING DOOR HEATER INSTRUCTIONS**

APPLIES TO: Installation \* Operation \* Maintenance

*the intended point where the gas comes out of the burner. Since the gas is not ignited, 'FR' goes into lockout because the UV flame scanner 'FS' does not 'see' any flame. Dry off the spark plug 'SP', ignition wire, and the general area at the burners' metal surface directly around the ignition point with a clean dry rag before attempting to re-light the burner.*

4. Check spark plug 'SP' for cracked insulation and dirt. Replace or clean as needed.
5. Manually reset the high temperature limit 'HTL', if necessary.
6. Check burner manifold gas pressure at pressure tap. (See Section 5; page 4).
7. Check incoming gas pressure at pressure tap ahead of heaters' gas pressure regulator 'REG'. (See Section 5; page 4).
8. Check alignment of UV flame scanner 'FS' to be certain it 'sees' the flame, especially at the beginning of each heating season.
9. Check main gas solenoid valve 'S-2' for burned out coil.
10. If gas flow is not modulating, refer to Maxitrol's instructions in the component literature portion of this manual for troubleshooting information.

#### **SPECIAL NOTE:**

The Honeywell RM7890A flame relay has a system status LED indication panel above the manual reset button for assisting in troubleshooting. A status chart is also located on the inside of the top door panel.

#### **THIS DOOR HEATER DOES NOT HAVE A PILOT BURNER!**

Refer to Honeywell literature elsewhere in this manual for further information on troubleshooting.

## 14.00 REPLACEMENT PARTS

### **!! CAUTION !!**

Use only factory approved parts when servicing or repairing a MODULATING DOOR HEATER. Any substitution of parts without factory approval will **"VOID"** all warranties. See Hazard Levels, Page 1.

117034 – Spark Ignitor

117079 – Gas Solenoid Valve – 1”NPT

117124 – Burner Replacement Kit includes:  
Spark Ignitor, Ignition Wire with Rubber Boot and Instructions

117135 – Control Transformer 230/460V.

117136 – Control Transformer 208V.

117140 – Ignition Transformer OR 117452 alternate

117142 – Door Limit Switch

117143 – Roller Arm for Door Limit Switch

117147 – High Temperature Limit

117154-5REPL – 5 Blade Propeller Fan Assembly Replacement Kit

117154-6REPL – 6 Blade Propeller Fan Assembly Replacement Kit (Replaces previous 10 blade assembly)

117155 – 1-1/2 HP 208-230/460/3 Phase Motor

117156 – 2 HP 208-230/460/3 Phase Motor

117201 – Motor Starter Contactor

117202 – 5.0 Overload Relay

117203 – 2.1 Overload Relay

117204 – 6.5 Overload Relay

117205 – 3.3 Overload Relay

117206 – Ignition Wire Ass’y w/Spark Boot

117228 – Circuit Control Fuse (Remote Cabinet)

## Page 9

### **GAS-FIRED MODULATING DOOR HEATER INSTRUCTIONS**

APPLIES TO: Installation \* Operation \* Maintenance

117244 – Remote Control Cabinet (includes all controls)

117246 – Ultra-Violet Flame Scanner

117265 – Modulating Gas Valve – 1”NPT

117268 – Amplifier for Modulating Gas Valve

117270 – Remote Temperature Selector

117369 – Flame Relay and Flame Amplifier

117426 – Time Delay Relay

117435 – ON-OFF Rocker Switch with Light

117454 – 2 HP 575 / 3 Phase Motor

117455 – Control Transformer 575V

132854-.19PS – Air Flow Switch

# GENERAL HEATER INSTALLATION OVERVIEW (HONEYWELL)

**THIS DRAWING IS FOR GENERAL REFERENCE ONLY!** It shows only general design guidelines and it does not provide specific installation details. Read all instructions carefully BEFORE attempting to install, operate, or service this equipment. Failure to follow installation, operation, and maintenance instructions or any substitute of factory installed parts without the written permission of the manufacturer will VOID all warranties. Failure to comply with this procedure may result in unsafe operation, personal injury, fire, asphyxiation and/or death. The safe application and use of this equipment is YOUR responsibility. The application and use of this equipment can vary greatly. For most applications and use, there are available diversified product models and optional safety accessories. This equipment may be sold with or without safety accessories. The diversity of applications for this equipment precludes establishing or warranting the efficacy of safe operating conditions which may result from its' use. The installer, user, owner, employer must determine the specific safety requirements for its' intended application. The specific safety requirements will vary depending on the location and operating procedures. Therefore, safety accessories are only supplied upon request.

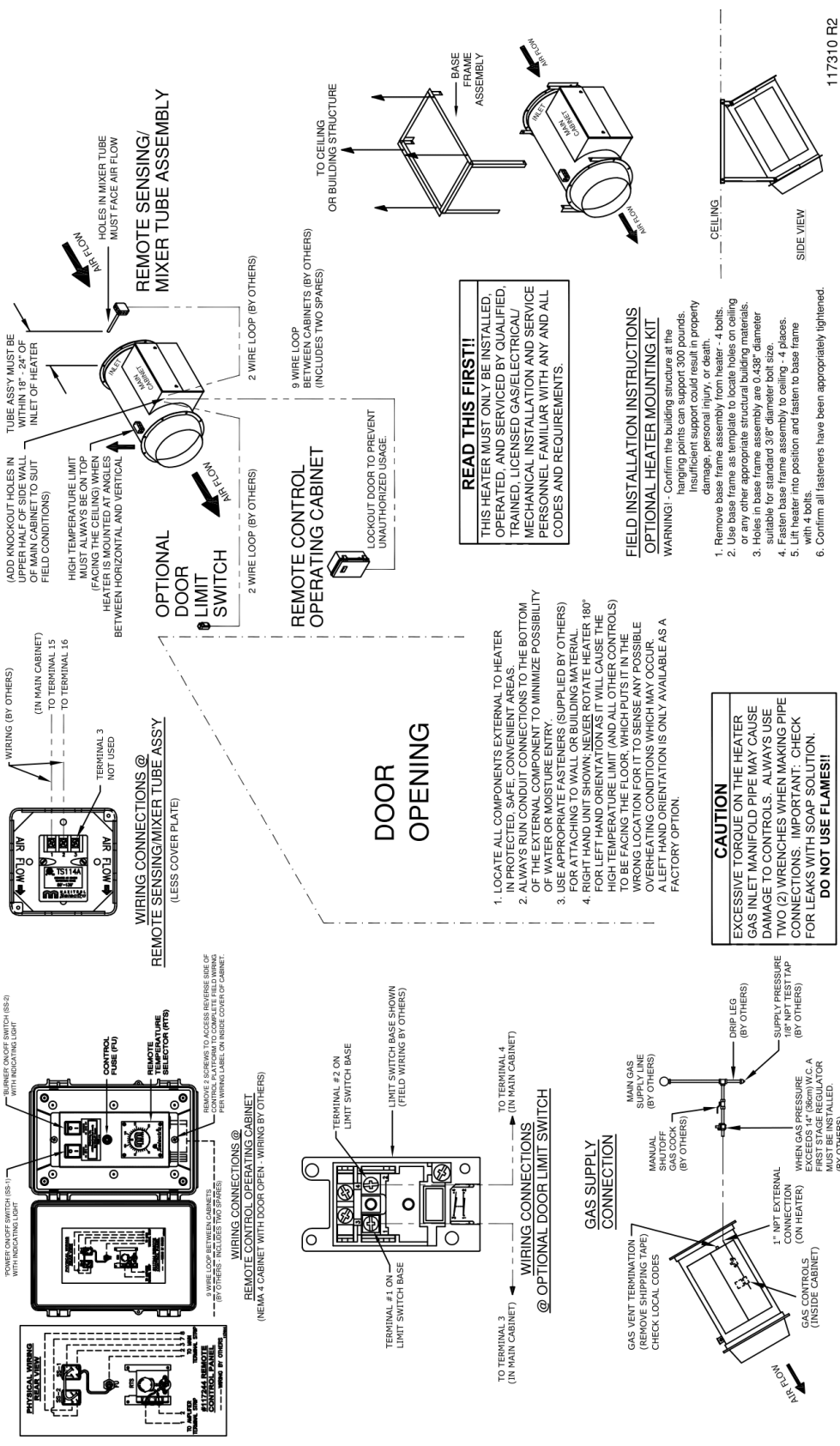

# STANDARD HEATER OVERVIEW

## READ THIS FIRST

- This heater must only be installed, operated, and serviced by qualified, trained, licensed gas/electrical/mechanical installation and service personnel familiar with any and all codes and requirements.

## MOUNTING (SEE FIGURE 4 IF NOT USING OPTIONAL KIT)

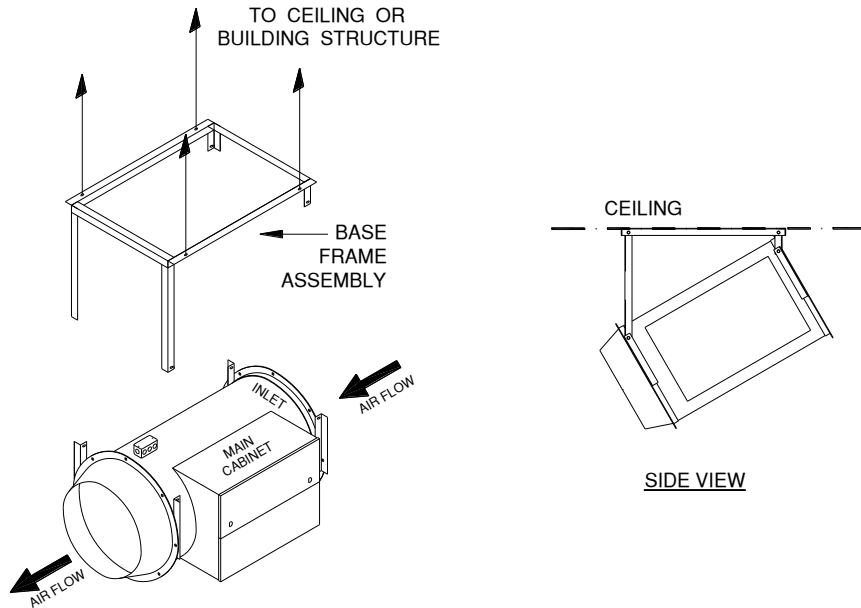

### FIELD INSTALLATION INSTRUCTIONS OPTIONAL HEATER MOUNTING KIT

**WARNING!** – Confirm the building structure at the hanging points can support 300 pounds. Insufficient support could result in property damage, personal injury, or death.

1. Remove base frame assembly from heater – 4 bolts.
2. Use base frame as template to locate holes on ceiling or any other appropriate structural building materials.
3. Holes in base frame assembly are 0.438" diameter suitable for standard 3/8" diameter bolt size.
4. Fasten base frame assembly to ceiling – 4 places.
5. Lift heater into position and fasten to base frame with 4 bolts.
6. Confirm all fasteners have been appropriately tightened.

## GAS SUPPLY CONNECTION

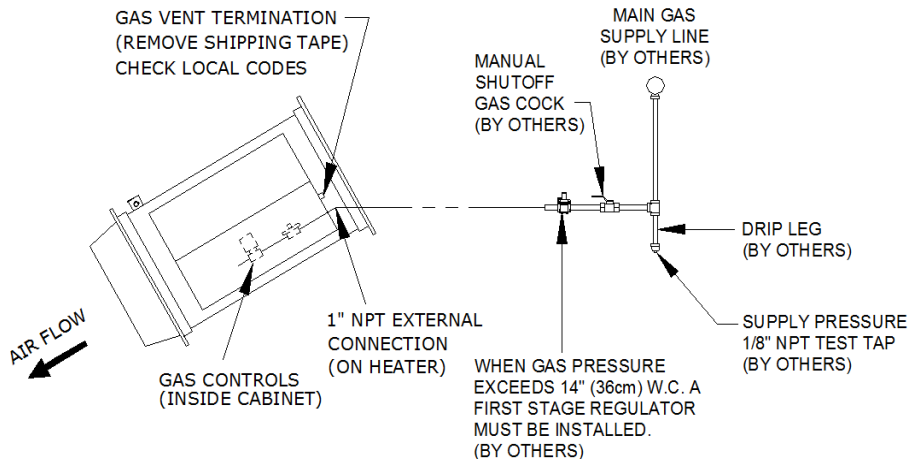

### CAUTION

- Excessive torque on the heater gas inlet manifold pipe may cause damage to controls. Always use two (2) wrenches when making pipe connections.
- IMPORTANT:** Check for leaks with soap solution. **DO NOT USE FLAMES!**

### NOTE

THESE DRAWINGS ARE FOR GENERAL REFERENCE ONLY! It shows only general design guidelines and it does not provide specific installation details. Read all instructions carefully **BEFORE** attempting to install, operate, or service this equipment. Failure to follow installation, operation, and maintenance instructions or any substitute of factory installed parts without the written permission of the manufacturer will **VOID** all warranties. Failure to comply with this procedure may result in unsafe operation, personal injury, fire, asphyxiation and/or death. The safe application and use of this equipment is **YOUR** responsibility. The application and use of this equipment can vary greatly. For most applications and use, the manufacturer has available diversified product models and optional safety accessories. This equipment may be sold with or without safety accessories. The diversity of applications for this equipment precludes the manufacturer from establishing or warranting the efficacy of safe operating conditions which may result from its' use. The installer, user, owner, employer must determine the specific safety requirements for its' intended application. The specific safety requirements will vary depending on the location and operating procedures. Therefore, safety accessories are only supplied upon request.

# EXTERNAL ACCESSORIES OVERVIEW

## LAYOUT / LOCATION

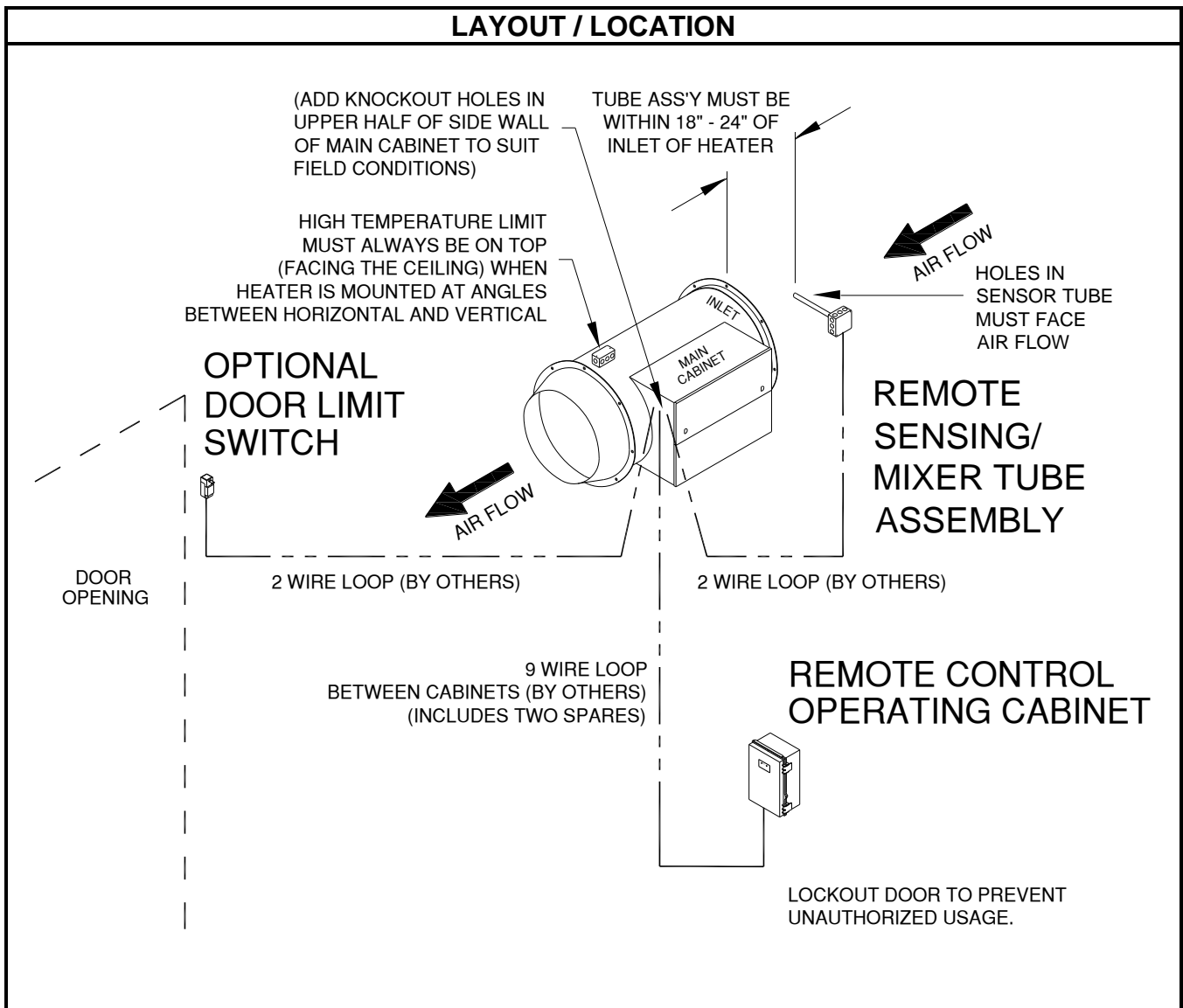

- Locate all components external to heater in safe, convenient areas.
- Always run conduit connections to the bottom of the external components to minimize possibility of water or moisture entry.
- Use appropriate fasteners (supplied by others) for attaching to wall or building material.

### NOTE

THIS DRAWING IS FOR GENERAL REFERENCE ONLY! It shows only general design guidelines and it does not provide specific installation details. Read all instructions carefully **BEFORE** attempting to install, operate, or service this equipment. Failure to follow installation, operation, and maintenance instructions or any substitute of factory installed parts without the written permission of the manufacturer will **VOID** all warranties. Failure to comply with this procedure may result in unsafe operation, personal injury, fire, asphyxiation and/or death. The safe application and use of this equipment is **YOUR** responsibility. The application and use of this equipment can vary greatly. For most applications and use, the manufacturer has available diversified product models and optional safety accessories. This equipment may be sold with or without safety accessories. The diversity of applications for this equipment precludes the manufacturer from establishing or warranting the efficacy of safe operating conditions which may result from its' use. The installer, user, owner, employer must determine the specific safety requirements for its' intended application. The specific safety requirements will vary depending on the location and operating procedures. Therefore, safety accessories are only supplied upon request.

# FIELD INSTALLATION of REMOTE SENSING/MIXER TUBE ASS'Y (REF. WIRING SCHEMATIC NO. D-141251)

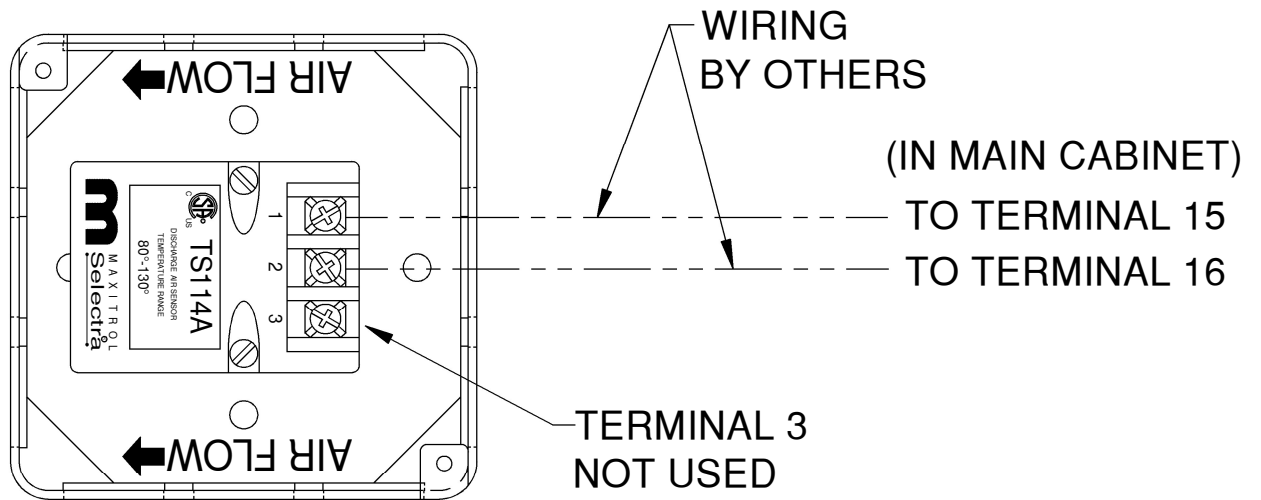
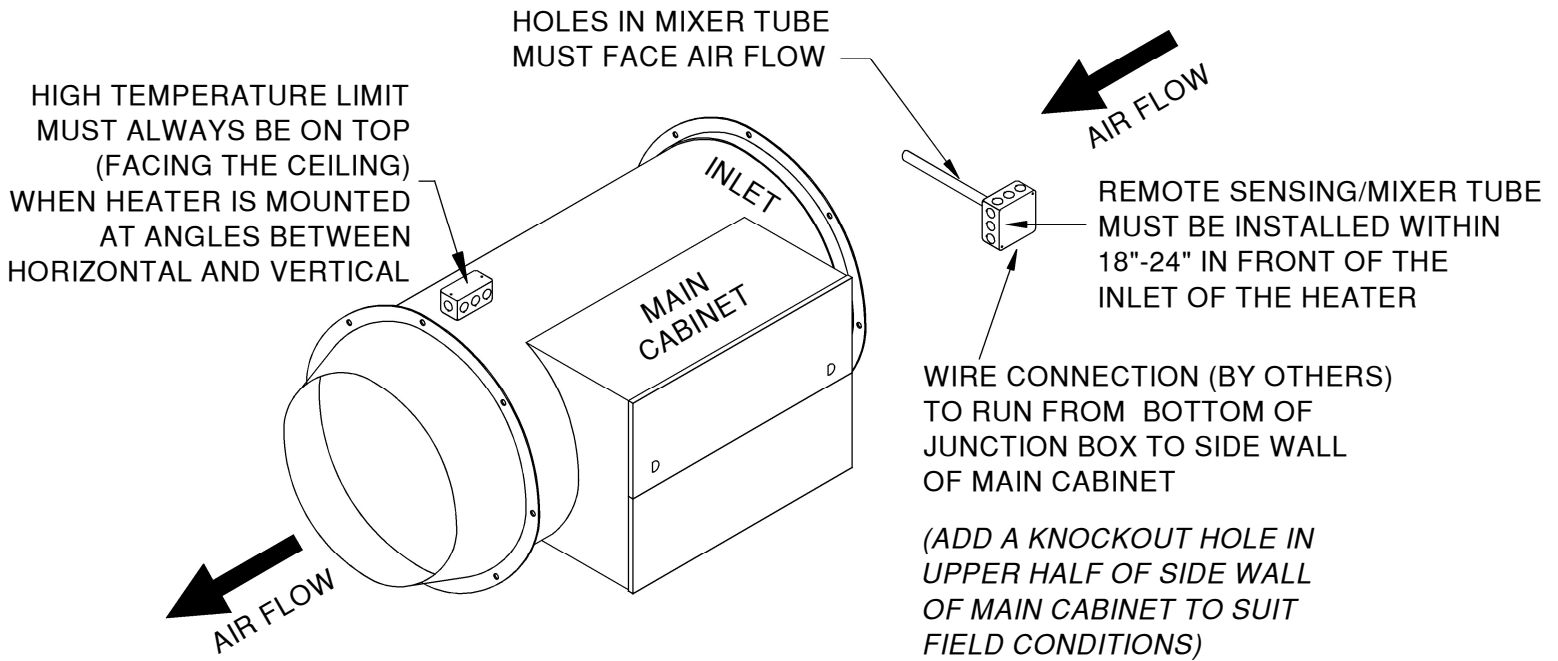

## WIRING CONNECTIONS @ REMOTE SENSING/MIXER TUBE ASS'Y (LESS COVER PLATE)

# FIELD INSTALLATION of REMOTE CONTROL OPERATING CABINET

(REF. WIRING SCHEMATIC NO. D-141251)

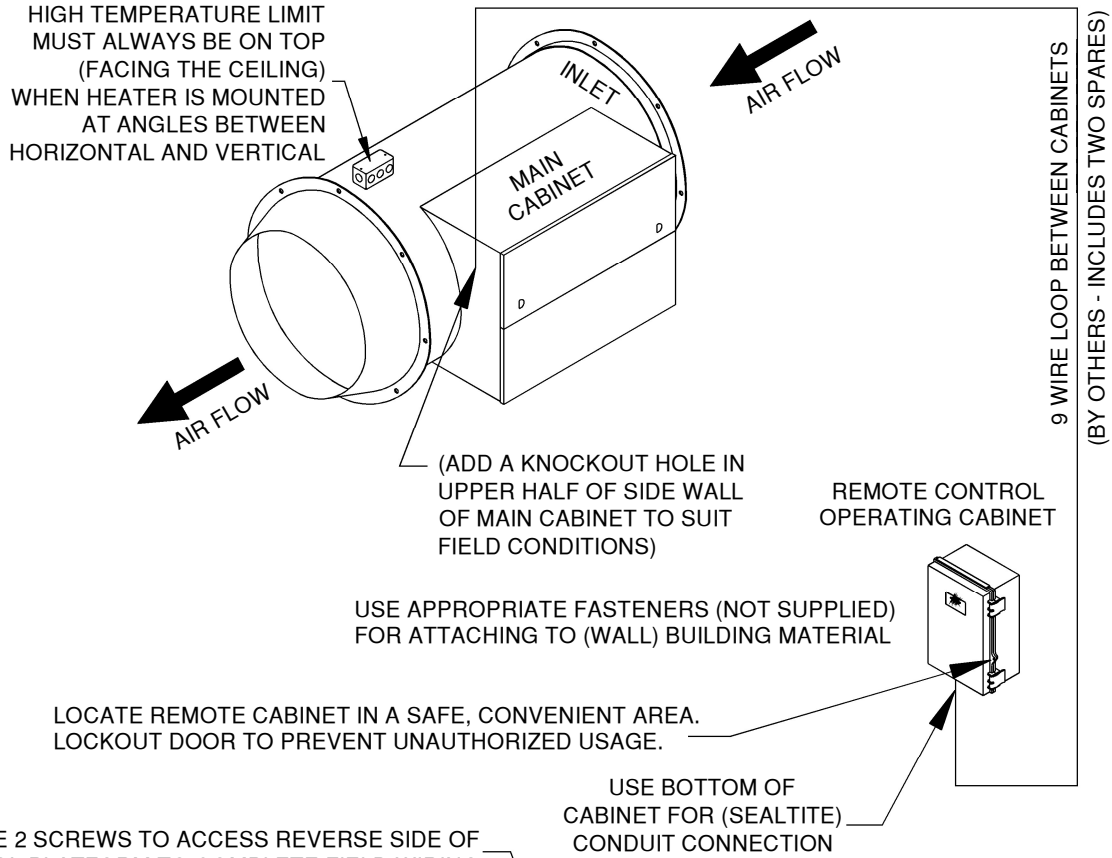

REMOVE 2 SCREWS TO ACCESS REVERSE SIDE OF CONTROL PLATFORM TO COMPLETE FIELD WIRING PER WIRING LABEL ON INSIDE COVER OF CABINET.

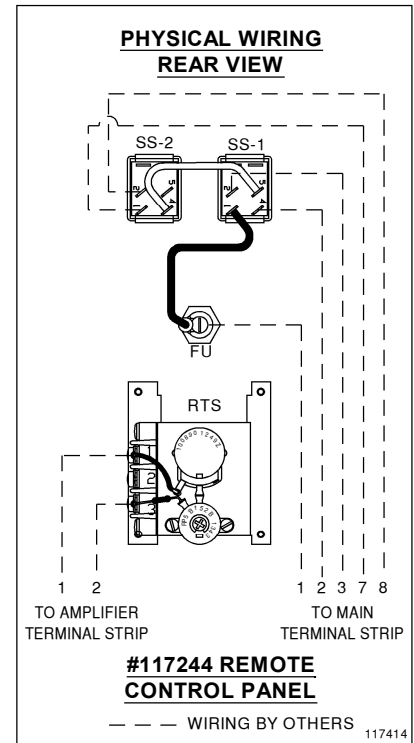
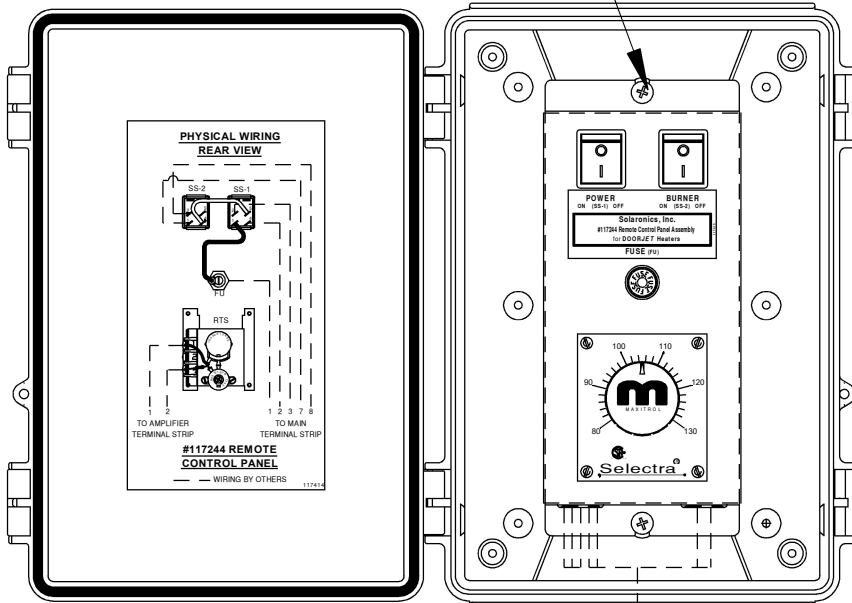

9 WIRE LOOP BETWEEN CABINETS  
(BY OTHERS - INCLUDES TWO SPARES)

**WIRING CONNECTIONS @  
REMOTE CONTROL OPERATING CABINET**  
(WIRING BY OTHERS)

A-117368 R2

# TYPICAL DOOR HEATER MOUNTING ARRANGEMENTS

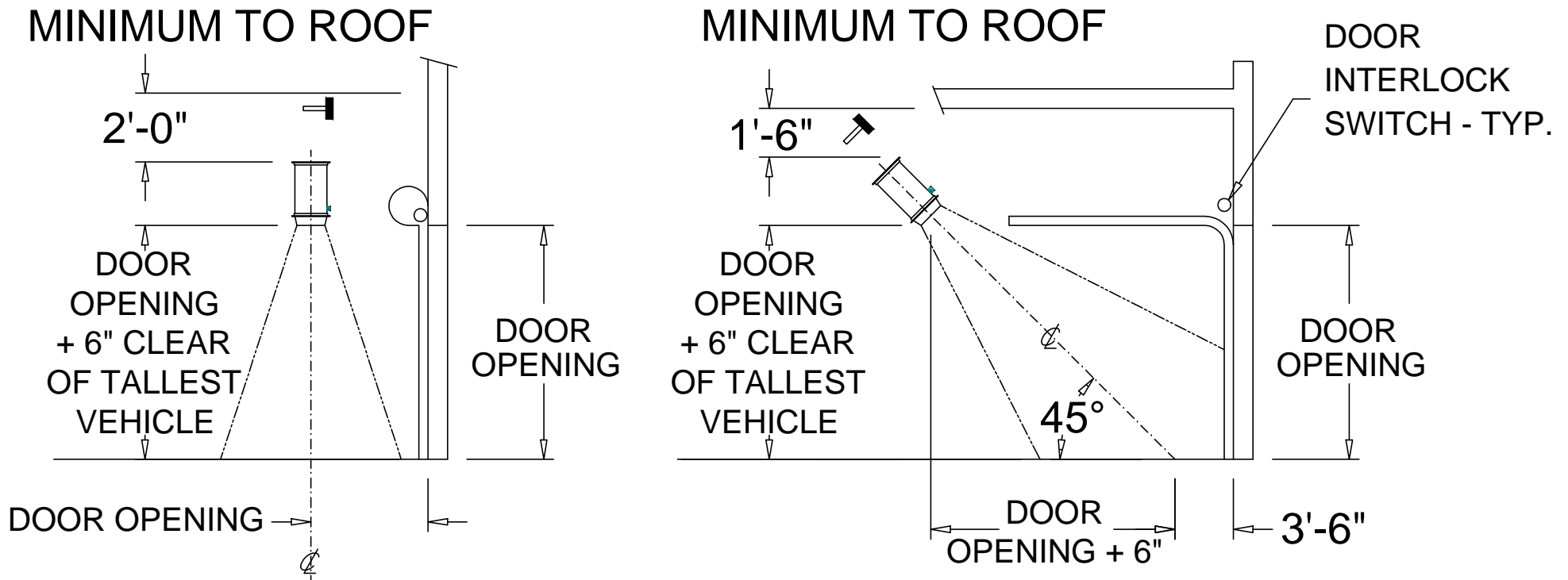

—■ MAXITROL MIXING TUBE & SENSOR  
INSTALL WITHIN 18"-24" OF INLET TO HEATER

## FIGURE 1

GENERAL GUIDELINES SHOWN FOR REFERENCE ONLY

# REMOTE CONTROL OPERATING CABINET

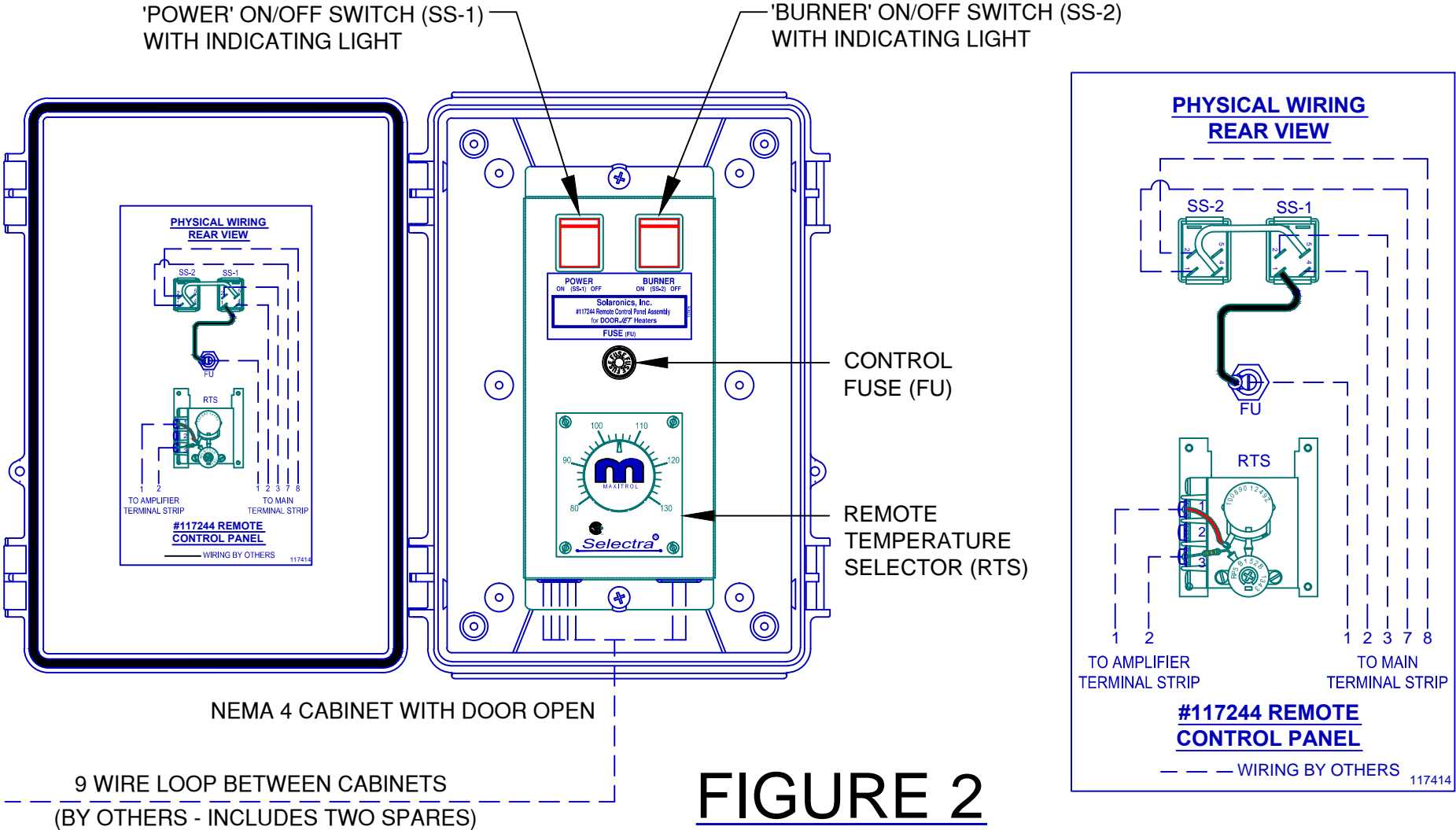

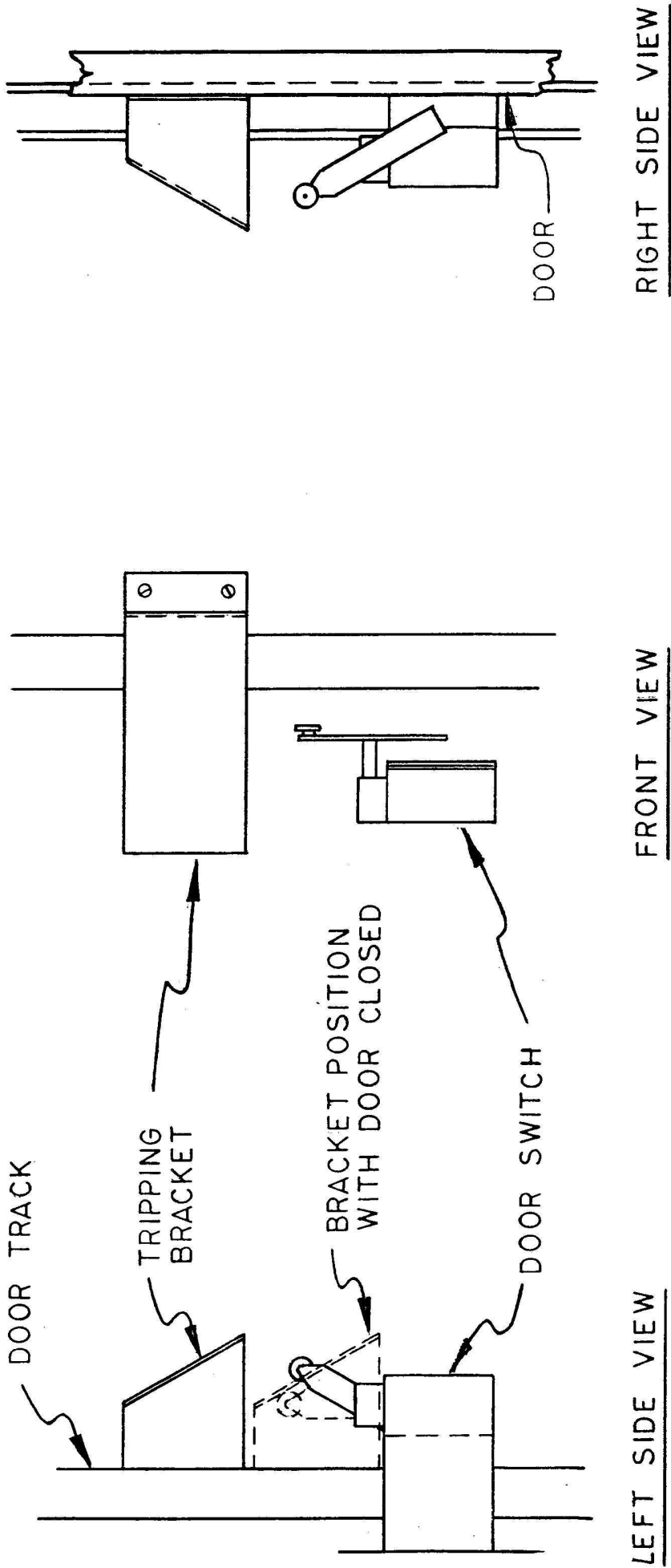

TYPICAL DOOR SWITCH INSTALLATION

FIGURE 3

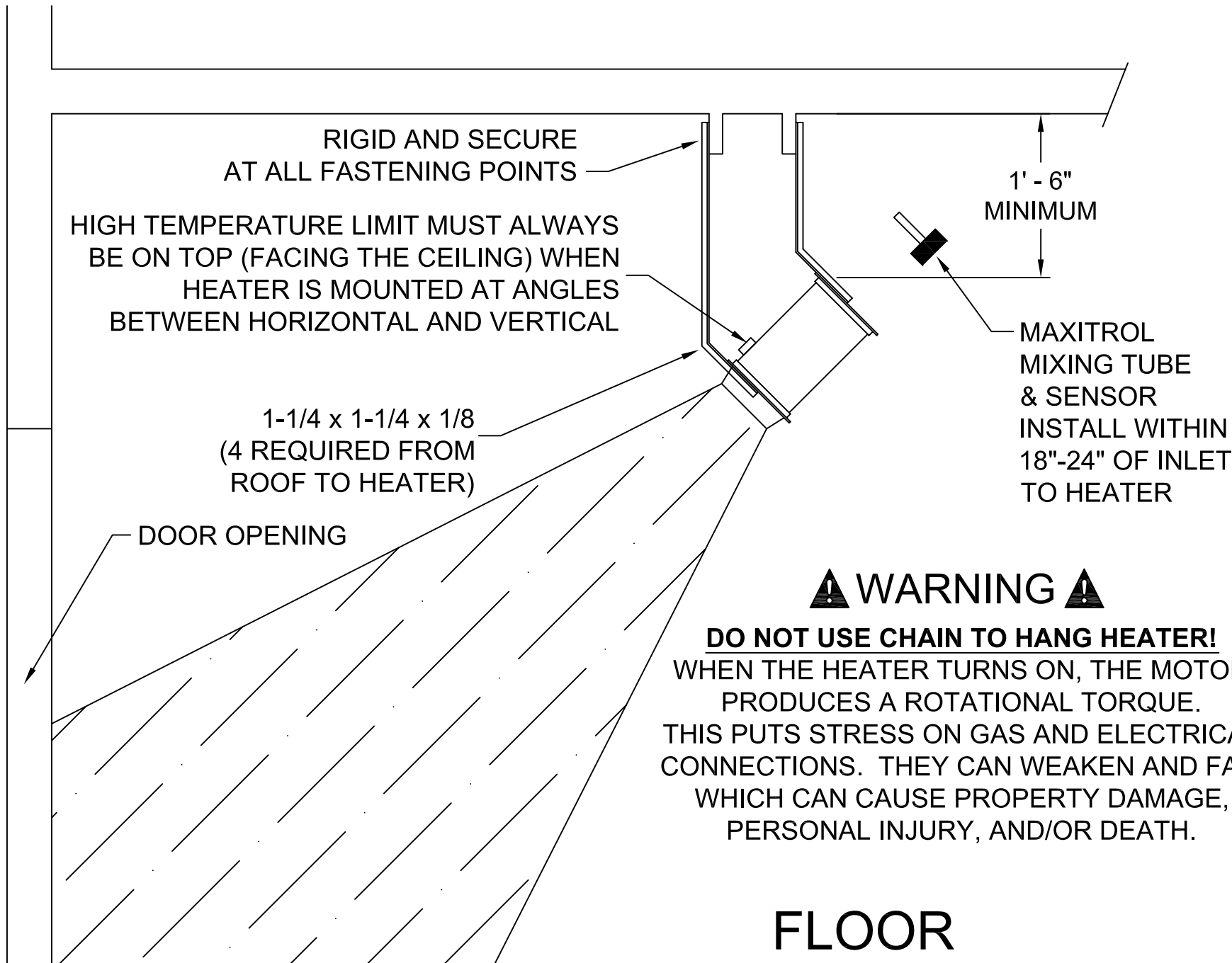

**FIGURE 4**

# BASIC HEATER DIMENSIONS AND ARRANGEMENT

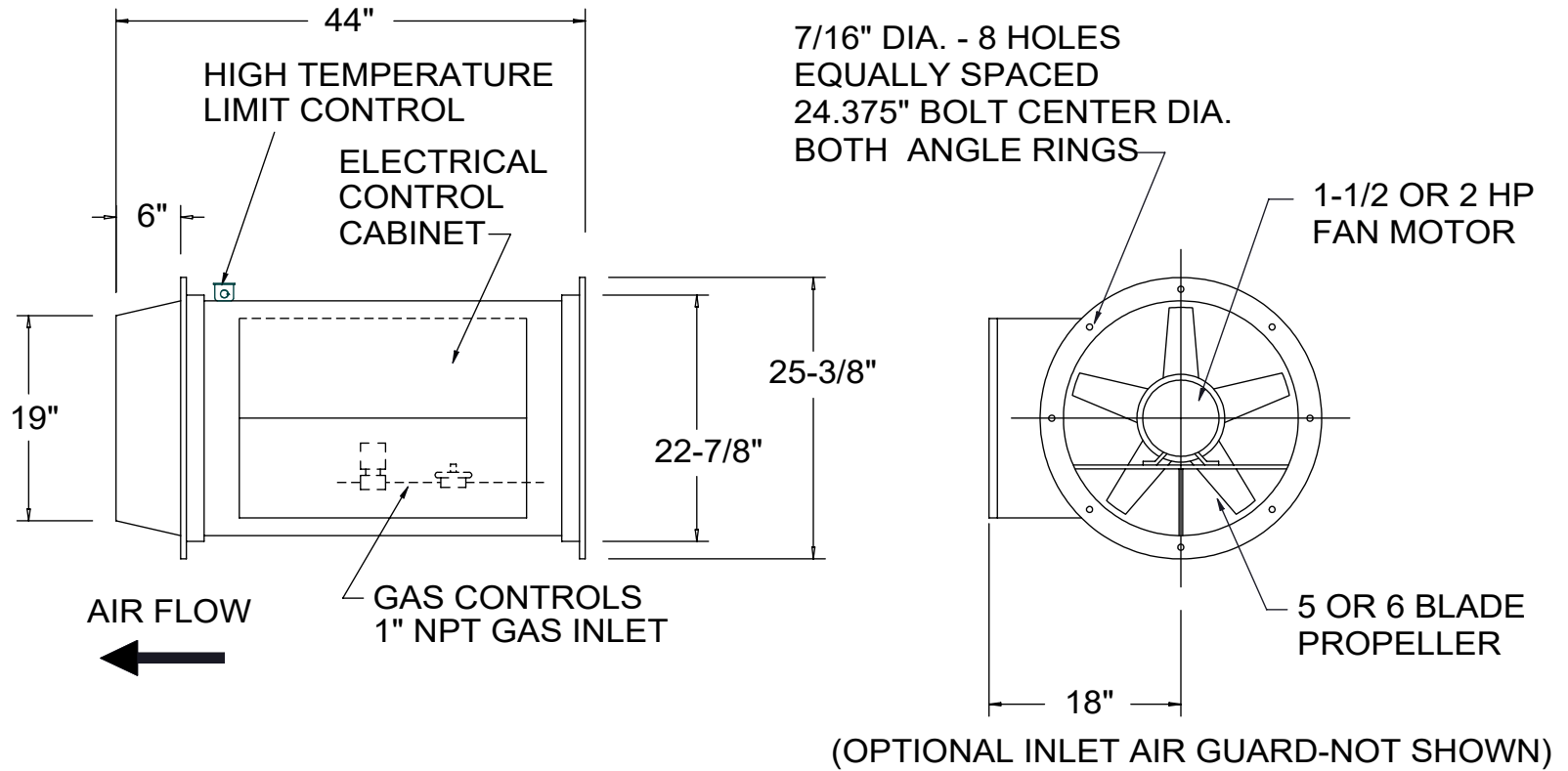

FIGURE 5



