

Atlas Copco

Oil-injected rotary screw compressors



GX 2 EP, GX 3 EP, GX 4 EP, GX 5 EP, GX 7 EP

Instruction book

Atlas Copco

Atlas Copco

Oil-injected rotary screw compressors

GX 2 EP, GX 3 EP, GX 4 EP, GX 5 EP, GX 7 EP

From following serial No. onwards: CAI 544 242

Instruction book

Original instructions

Copyright notice

Any unauthorized use or copying of the contents or any part thereof is prohibited.

This applies in particular to trademarks, model denominations, part numbers and drawings.

This instruction book is valid for CE as well as non-CE labelled machines. It meets the requirements for instructions specified by the applicable European directives as identified in the Declaration of Conformity.

2012 - 03

No. 2920 7105 30

www.atlascopco.com



Table of contents



1	Safety precautions.....	4
1.1	SAFETY ICONS.....	4
1.2	SAFETY PRECAUTIONS, GENERAL.....	4
1.3	SAFETY PRECAUTIONS DURING INSTALLATION.....	5
1.4	SAFETY PRECAUTIONS DURING OPERATION.....	6
1.5	SAFETY PRECAUTIONS DURING MAINTENANCE OR REPAIR.....	7
2	General description.....	9
2.1	INTRODUCTION.....	9
2.2	AIR FLOW.....	11
2.3	OIL SYSTEM.....	14
2.4	COOLING SYSTEM.....	16
2.5	REGULATING SYSTEM.....	17
2.6	CONTROL PANEL	19
2.7	ELECTRICAL DIAGRAMS.....	20
2.8	PROTECTION OF COMPRESSOR.....	27
2.9	AIR DRYER.....	29
3	Installation.....	30
3.1	INSTALLATION PROPOSAL.....	30
3.2	DIMENSION DRAWINGS.....	33
3.3	ELECTRICAL CONNECTIONS	37
3.4	PICTOGRAPHS.....	38
4	Operating instructions.....	40
4.1	INITIAL START-UP.....	40
4.2	STARTING.....	42
4.3	STOPPING.....	44

4.4	TAKING OUT OF OPERATION.....	46
5	Maintenance.....	48
5.1	PREVENTIVE MAINTENANCE SCHEDULE.....	48
5.2	DRIVE MOTOR	49
5.3	OIL SPECIFICATIONS.....	49
5.4	OIL, FILTER AND SEPARATOR CHANGE	50
5.5	STORAGE AFTER INSTALLATION.....	52
5.6	SERVICE KITS.....	52
6	Adjustments and servicing procedures.....	53
6.1	AIR FILTER.....	53
6.2	COOLERS.....	54
6.3	SAFETY VALVE	54
6.4	BELT SET EXCHANGE AND TENSIONING	55
7	Problem solving.....	57
8	Technical data.....	60
8.1	READINGS ON CONTROL PANEL.....	60
8.2	ELECTRIC CABLE SIZE.....	60
8.3	SETTINGS FOR OVERLOAD RELAY AND FUSES.....	61
8.4	REFERENCE CONDITIONS AND LIMITATIONS.....	63
8.5	COMPRESSOR DATA.....	63
9	Instructions for use.....	67
10	Guidelines for inspection.....	68
11	Pressure equipment directives.....	69
12	Declaration of conformity.....	70

1 Safety precautions

1.1 Safety icons

Explanation

	Danger for life
	Warning
	Important note

1.2 Safety precautions, general

General precautions

1. The operator must employ safe working practices and observe all related work safety requirements and regulations.
2. If any of the following statements does not comply with the applicable legislation, the stricter of the two shall apply.
3. Installation, operation, maintenance and repair work must only be performed by authorized, trained, specialized personnel.
4. The compressor is not considered capable of producing air of breathing quality. For air of breathing quality, the compressed air must be adequately purified according to the applicable legislation and standards.
5. Before any maintenance, repair work, adjustment or any other non-routine checks, stop the compressor, press the emergency stop button, switch off the voltage and depressurize the compressor. In addition, the power isolating switch must be opened and locked.
On units powered by a frequency converter, wait six minutes before starting any electrical repair.

	If the machine is equipped with an automatic restart after voltage failure function and if this function is active, be aware that the machine will restart automatically when the power is restored if it was running when the power was interrupted!
---	---

6. Never play with compressed air. Do not apply the air to your skin or direct an air stream at people. Never use the air to clean dirt from your clothes. When using the air to clean equipment, do so with extreme caution and wear eye protection.
7. The owner is responsible for maintaining the unit in safe operating condition. Parts and accessories shall be replaced if unsuitable for safe operation.
8. It is not allowed to walk or stand on the unit or on its components.

1.3 Safety precautions during installation



All responsibility for any damage or injury resulting from neglecting these precautions, or non observance of the normal caution and care required for installation, operation, maintenance and repair, even if not expressly stated, will be disclaimed by the manufacturer.

Precautions during installation

1. The machine must only be lifted using suitable equipment in accordance with the applicable safety regulations. Loose or pivoting parts must be securely fastened before lifting. It is strictly forbidden to dwell or stay in the risk zone under a lifted load. Lifting acceleration and deceleration must be kept within safe limits. Wear a safety helmet when working in the area of overhead or lifting equipment.
2. The unit is designed for indoor use. If the unit is installed outdoors, special precautions must be taken; consult your supplier.
3. Place the machine where the ambient air is as cool and clean as possible. If necessary, install a suction duct. Never obstruct the air inlet. Care must be taken to minimize the entry of moisture at the inlet air.
4. Any blanking flanges, plugs, caps and desiccant bags must be removed before connecting the pipes.
5. Air hoses must be of correct size and suitable for the working pressure. Never use frayed, damaged or worn hoses. Distribution pipes and connections must be of the correct size and suitable for the working pressure.
6. The aspirated air must be free of flammable fumes, vapours and particles, e.g. paint solvents, that can lead to internal fire or explosion.
7. Arrange the air intake so that loose clothing worn by people cannot be sucked in.
8. Ensure that the discharge pipe from the compressor to the aftercooler or air net is free to expand under heat and that it is not in contact with or close to flammable materials.
9. No external force may be exerted on the air outlet valve; the connected pipe must be free of strain.
10. If remote control is installed, the machine must bear a clear sign stating: **DANGER: This machine is remotely controlled and may start without warning.**
The operator has to make sure that the machine is stopped and that the isolating switch is open and locked before any maintenance or repair. As a further safeguard, persons switching on remotely controlled machines shall take adequate precautions to ensure that there is no one checking or working on the machine. To this end, a suitable notice shall be affixed to the start equipment.
11. Air-cooled machines must be installed in such a way that an adequate flow of cooling air is available and that the exhausted air does not recirculate to the compressor air inlet or cooling air inlet.
12. The electrical connections must correspond to the applicable codes. The machines must be earthed and protected against short circuits by fuses in all phases. A lockable power isolating switch must be installed near the compressor.
13. On machines with automatic start/stop system or if the automatic restart function after voltage failure is activated, a sign stating "This machine may start without warning" must be affixed near the instrument panel.
14. In multiple compressor systems, manual valves must be installed to isolate each compressor. Non-return valves (check valves) must not be relied upon for isolating pressure systems.
15. Never remove or tamper with the safety devices, guards or insulation fitted on the machine. Every pressure vessel or auxiliary installed outside the machine to contain air above atmospheric pressure must be protected by a pressure relieving device or devices as required.
16. Piping or other parts with a temperature in excess of 70°C (158°F) and which may be accidentally touched by personnel in normal operation must be guarded or insulated. Other high temperature piping must be clearly marked.
17. For water-cooled machines, the cooling water system installed outside the machine has to be protected by a safety device with set pressure according to the maximum cooling water inlet pressure.

18. If the ground is not level or can be subject to variable inclination, consult the manufacturer.



Also consult following safety precautions: [Safety precautions during operation](#) and [Safety precautions during maintenance](#).

These precautions apply to machinery processing or consuming air or inert gas. Processing of any other gas requires additional safety precautions typical to the application which are not included herein.

Some precautions are general and cover several machine types and equipment; hence some statements may not apply to your machine.

1.4 Safety precautions during operation



All responsibility for any damage or injury resulting from neglecting these precautions, or non observance of the normal caution and care required for installation, operation, maintenance and repair, even if not expressly stated, will be disclaimed by the manufacturer.

Precautions during operation

1. Never touch any piping or components of the compressor during operation.
2. Use only the correct type and size of hose end fittings and connections. When blowing through a hose or air line, ensure that the open end is held securely. A free end will whip and may cause injury. Make sure that a hose is fully depressurized before disconnecting it.
3. Persons switching on remotely controlled machines shall take adequate precautions to ensure that there is no one checking or working on the machine. To this end, a suitable notice shall be affixed to the remote start equipment.
4. Never operate the machine when there is a possibility of taking in flammable or toxic fumes, vapors or particles.
5. Never operate the machine below or in excess of its limit ratings.
6. Keep all bodywork doors shut during operation. The doors may be opened for short periods only, e.g. to carry out routine checks. Wear ear protectors when opening a door.
On compressors without bodywork, wear ear protection in the vicinity of the machine.
7. People staying in environments or rooms where the sound pressure level reaches or exceeds 80 dB(A) shall wear ear protectors.
8. Periodically check that:
 - All guards are in place and securely fastened
 - All hoses and/or pipes inside the machine are in good condition, secure and not rubbing
 - There are no leaks
 - All fasteners are tight
 - All electrical leads are secure and in good order
 - Safety valves and other pressure relief devices are not obstructed by dirt or paint
 - Air outlet valve and air net, i.e. pipes, couplings, manifolds, valves, hoses, etc. are in good repair, free of wear or abuse
9. If warm cooling air from compressors is used in air heating systems, e.g. to warm up a workroom, take precautions against air pollution and possible contamination of the breathing air.
10. On water-cooled compressors using open circuit cooling towers, protective measures must be taken to avoid the growth of harmful bacteria such as Legionella or pneumophila bacteria.
11. Do not remove any of, or tamper with, the sound-damping material.

12. Never remove or tamper with the safety devices, guards or insulations fitted on the machine. Every pressure vessel or auxiliary installed outside the machine to contain air above atmospheric pressure shall be protected by a pressure relieving device or devices as required.



Also consult following safety precautions: [Safety precautions during installation](#) and [Safety precautions during maintenance](#).

These precautions apply to machinery processing or consuming air or inert gas. Processing of any other gas requires additional safety precautions typical to the application which are not included herein.

Some precautions are general and cover several machine types and equipment; hence some statements may not apply to your machine.

1.5 Safety precautions during maintenance or repair



All responsibility for any damage or injury resulting from neglecting these precautions, or non observance of the normal caution and care required for installation, operation, maintenance and repair, even if not expressly stated, will be disclaimed by the manufacturer.

Precautions during maintenance or repair

1. Always use the correct safety equipment (such as safety glasses, gloves, safety shoes, etc.).
2. Use only the correct tools for maintenance and repair work.
3. Use only genuine spare parts.
4. All maintenance work shall only be undertaken when the machine has cooled down.
5. A warning sign bearing a legend such as "Work in progress; do not start" shall be attached to the starting equipment.
6. Persons switching on remotely controlled machines shall take adequate precautions to ensure that there is no one checking or working on the machine. To this end, a suitable notice shall be affixed to the remote start equipment.
7. Close the compressor air outlet valve before connecting or disconnecting a pipe.
8. Before removing any pressurized component, effectively isolate the machine from all sources of pressure and relieve the entire system of pressure.
9. Never use flammable solvents or carbon tetrachloride for cleaning parts. Take safety precautions against toxic vapours of cleaning liquids.
10. Scrupulously observe cleanliness during maintenance and repair. Keep dirt away by covering the parts and exposed openings with a clean cloth, paper or tape.
11. Never weld or perform any operation involving heat near the oil system. Oil tanks must be completely purged, e.g. by steam cleaning, before carrying out such operations. Never weld on, or in any way modify, pressure vessels.
12. Whenever there is an indication or any suspicion that an internal part of a machine is overheated, the machine shall be stopped but no inspection covers shall be opened before sufficient cooling time has elapsed; this to avoid the risk of spontaneous ignition of the oil vapour when air is admitted.
13. Never use a light source with open flame for inspecting the interior of a machine, pressure vessel, etc.
14. Make sure that no tools, loose parts or rags are left in or on the machine.
15. All regulating and safety devices shall be maintained with due care to ensure that they function properly. They may not be put out of action.
16. Before clearing the machine for use after maintenance or overhaul, check that operating pressures, temperatures and time settings are correct. Check that all control and shut-down devices are fitted and that

they function correctly. If removed, check that the coupling guard of the compressor drive shaft has been reinstalled.

17. Every time the separator element is renewed, examine the discharge pipe and the inside of the oil separator vessel for carbon deposits; if excessive, the deposits should be removed.
18. Protect the motor, air filter, electrical and regulating components, etc. to prevent moisture from entering them, e.g. when steam cleaning.
19. Make sure that all sound-damping material and vibration dampers, e.g. damping material on the bodywork and in the air inlet and outlet systems of the compressor, is in good condition. If damaged, replace it by genuine material from the manufacturer to prevent the sound pressure level from increasing.
20. Never use caustic solvents which can damage materials of the air net, e.g. polycarbonate bowls.
21. **The following safety precautions are stressed when handling refrigerant:**
 - Never inhale refrigerant vapours. Check that the working area is adequately ventilated; if required, use breathing protection.
 - Always wear special gloves. In case of refrigerant contact with the skin, rinse the skin with water. If liquid refrigerant contacts the skin through clothing, never tear off or remove the latter; flush abundantly with fresh water over the clothing until all refrigerant is flushed away; then seek medical first aid.



Also consult following safety precautions: [Safety precautions during installation](#) and [Safety precautions during operation](#).

These precautions apply to machinery processing or consuming air or inert gas. Processing of any other gas requires additional safety precautions typical to the application which are not included herein.

Some precautions are general and cover several machine types and equipment; hence some statements may not apply to your machine.

2 General description

2.1 Introduction

Introduction

GX 2 EP, GX 3 EP, GX 4 EP, GX 5 EP and GX 7 EP are air-cooled, single-stage, oil-injected screw compressors, driven by an electric motor.

The compressors are belt driven.

The compressors are enclosed in sound-insulating bodywork.

An easy-to-operate control panel is provided, including the start/stop switch and the emergency stop button. A cabinet housing the regulator, pressure switch and motor starter is integrated into the bodywork.

Pack versions do not include an air dryer.

Full-Feature versions are fitted with an air dryer (DR). The dryer removes moisture from the compressed air by cooling the air to near the freezing point and automatically draining the condensate.

Floor-mounted model

The compressor is installed directly on the floor.

The floor-mounted model is available as Pack version only.



GX 5 Pack EP, floor-mounted

Ref.	Description
1	Control panel

Tank-mounted model

Tank-mounted units are supplied with an air receiver of 200 l (52.80 US gal / 44 Imp gal / 7 cu.ft) and are available in Pack and Full-Feature version.



GX 5 FF EP, tank-mounted

Ref.	Description
1	Control panel
AO	Air outlet
AR	Air receiver
Dm2	Condensate drain valve, air receiver
SV	Safety valve
DR	Integrated dryer

2.2 Air flow

Pack

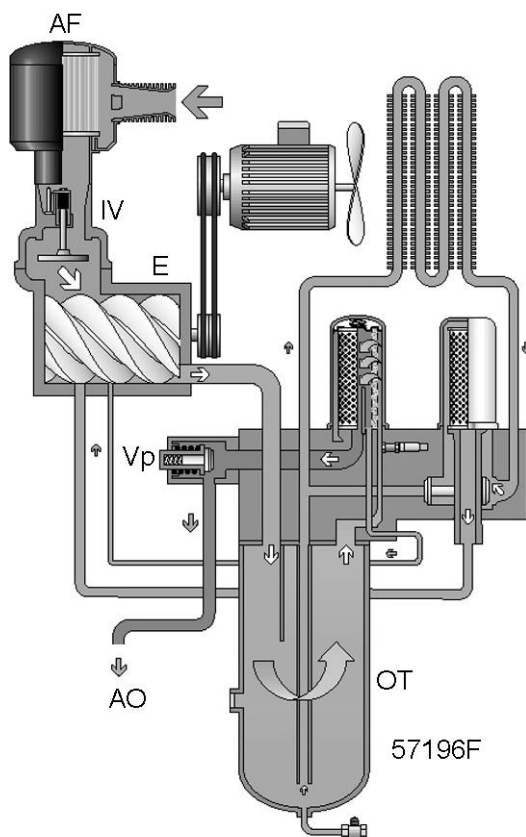

Air flow, floor-mounted Pack units

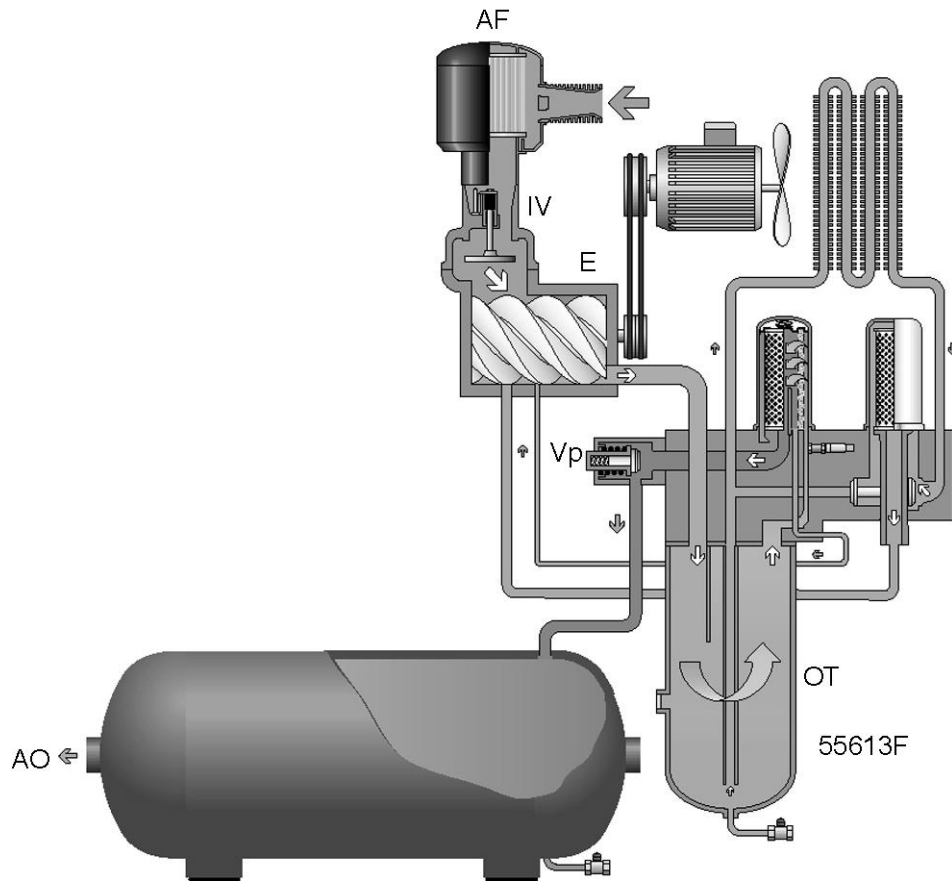

Air flow, tank-mounted Pack units

Air drawn in through air filter (AF) and open inlet valve (IV) is compressed in compressor element (E). Compressed air and oil flow into oil separator/tank (OT) where most of the oil is removed by centrifugal action. The remaining oil is removed by oil separator (OS). The air flows to the outlet (AO) via minimum pressure valve (Vp).

Full-Feature

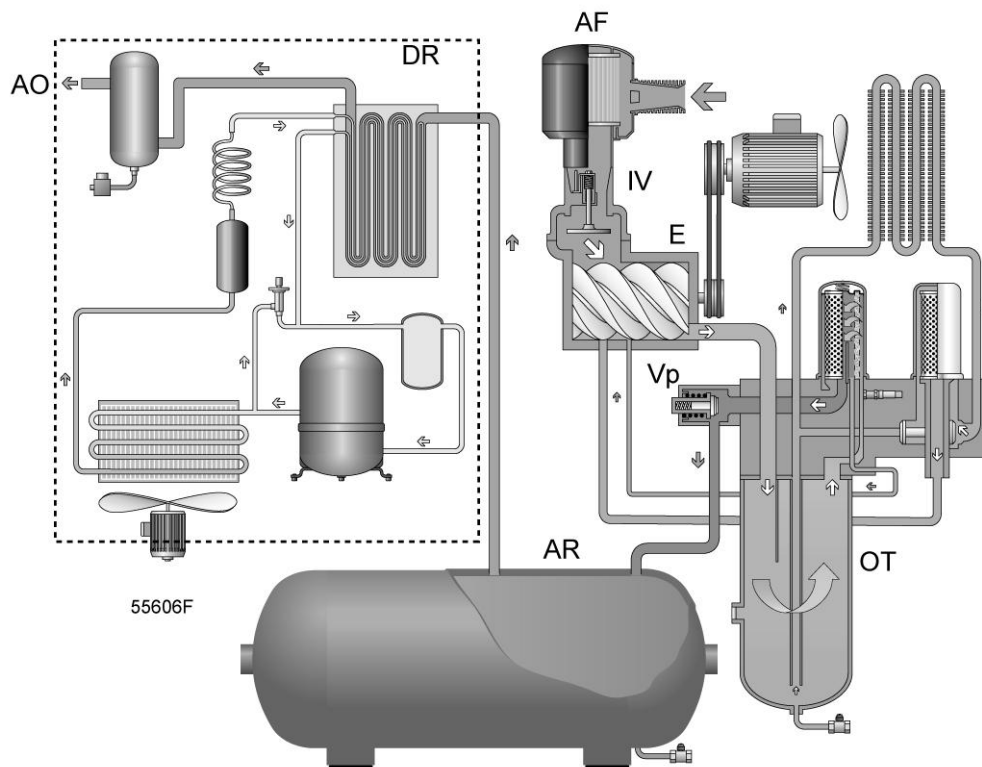

Air flow, GX tank-mounted Full-Feature units

Air drawn in through air filter (AF) and open inlet valve (IV) is compressed in compressor element (E). Compressed air and oil flow into oil separator/tank (OT) where most of the oil is removed by centrifugal action. The remaining oil is removed by oil separator (OS). The air is discharged via minimum pressure valve (Vp), air receiver (AR) and dryer (DR) towards the air outlet (AO).

2.3 Oil system

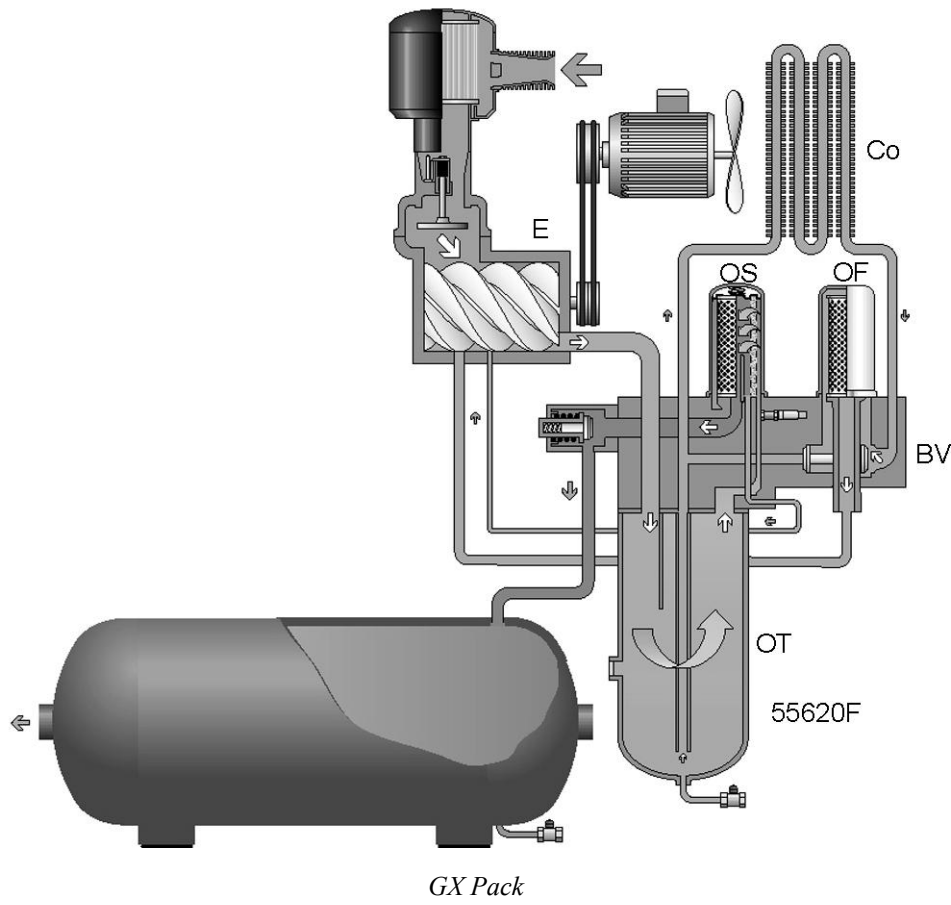

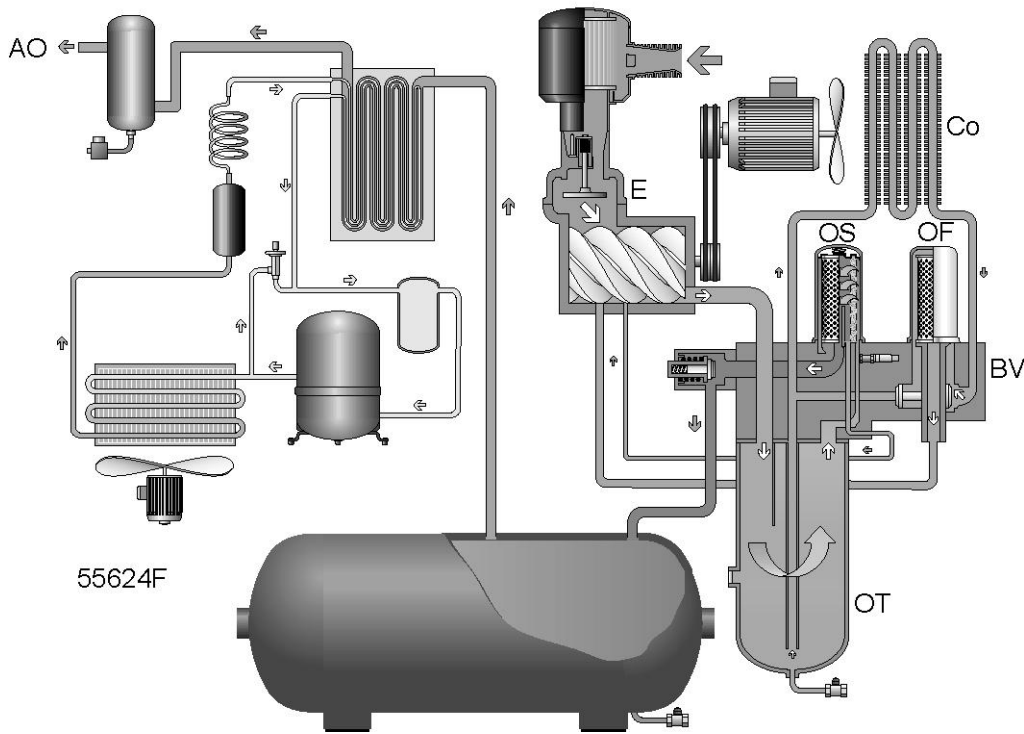

GX Full-Feature

Air pressure in the oil separator tank (OT) forces the oil from the tank to compressor element (E) via oil cooler (Co) and oil filter (OF). Compressed air and oil flow into oil separator/tank (OT) where most of the oil is separated from the air by centrifugal action. The remaining oil is removed by oil separator (OS) and returns to the oil circuit via a separate line. The minimum pressure valve (Vp - see section [Air flow](#)) ensures a minimal pressure in the tank, required for oil circulation under all circumstances.

The oil circuit has a thermostatic bypass valve (BV). The oil cooler is bypassed until the oil is warm.

2.4 Cooling system

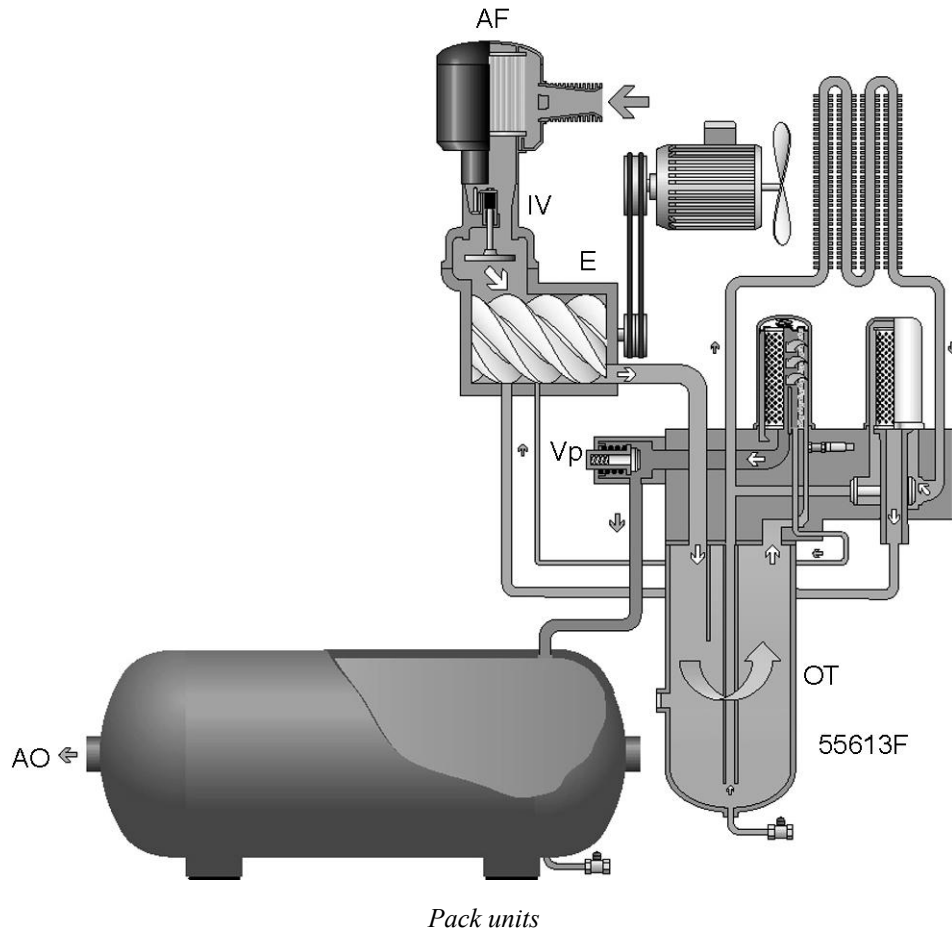

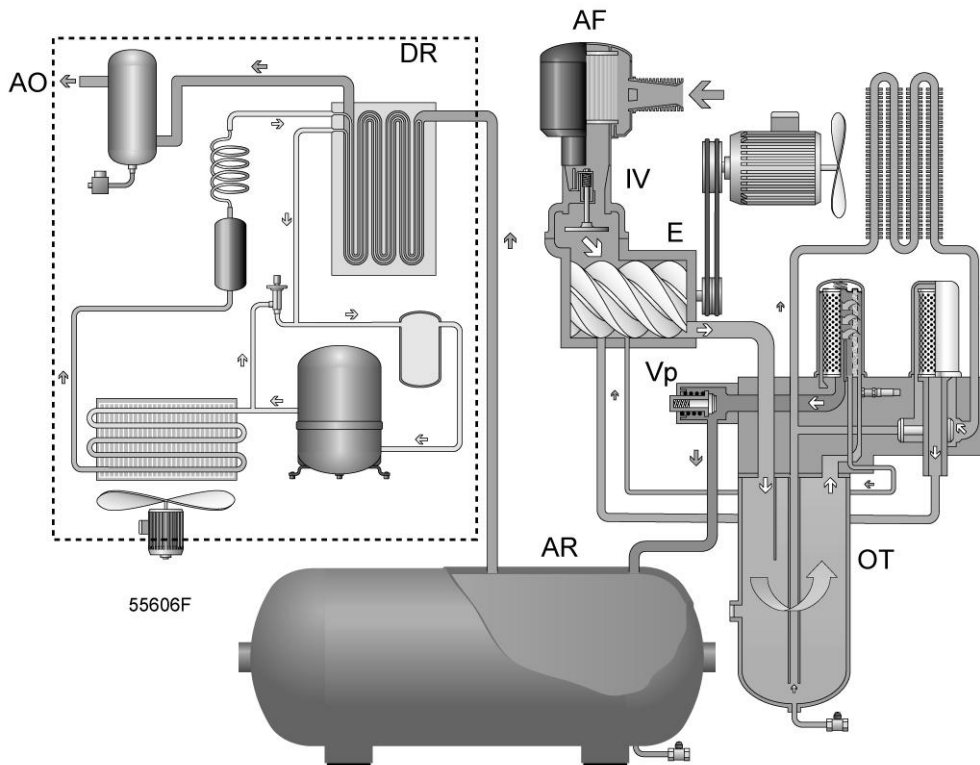

Full-Feature units

A fan on the drive motor shaft provides air flow to cool the oil and the other components of the compressor. On tank-mounted compressors, the air receiver is used as air cooler. The condensate is drained manually.

The dryer (DR) of Full-Feature versions has a separate cooling fan and an automatic condensate drain (see also section [Air dryer](#)).

2.5 Regulating system

GX 2 up to GX 5

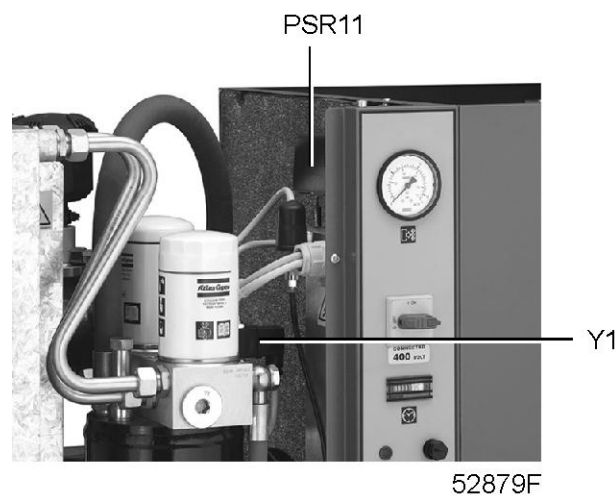

The main components of the regulating system are:

- Pressure switch (PSR11)
- Blow-off valve (Y1)

The contacts of pressure switch (PSR11) open and close at preset pressures. During loaded operation, the contacts are closed: the motor is running.

When the working pressure reaches the upper limit, the contacts of the pressure switch open: the motor stops. Blow-off valve (Y1) opens and the pressure in the air/oil separator is released. When the working pressure decreases to the pre-set minimum pressure, the contacts of the pressure switch close and the motor restarts. Blow-off valve Y1 closes and compressed air supply is resumed.

GX 7

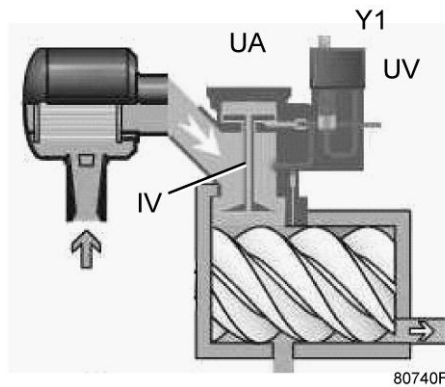

Detail view of unloader assembly (UA)

The main components of the regulating system are:

- Pressure switch, which opens and closes at preset pressure limits. See also section [Protection of the compressor](#).
- Unloader (UA), including inlet valve (IV) and unloading valve (UV).
- Loading solenoid valve (Y1).

As long as the working pressure is below the preset maximum, the solenoid valve is energised, allowing control air to the unloader: the inlet valve opens completely and the unloading valve closes completely. The compressor will run fully loaded (100% output).

When the working pressure reaches the maximum limit, the solenoid valve is de-energised, venting the control air: the inlet valve closes completely and the unloading valve opens completely. The compressor will run unloaded (0% output). If the compressor keeps running unloaded for an uninterrupted period of 240 seconds, it will be stopped. If the pressure reaches the minimum pressure level before the 240 seconds are reached, the compressor will automatically start running loaded again.

The compressor will automatically restart when the net pressure drops to the minimum limit.

2.6 Control panel

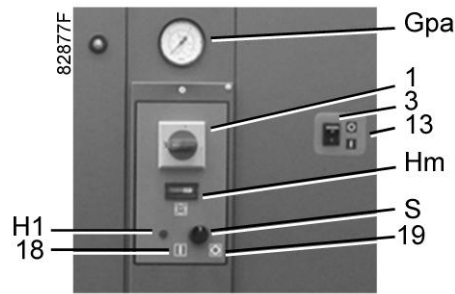

Control panel GX 2 up to GX 5 EP

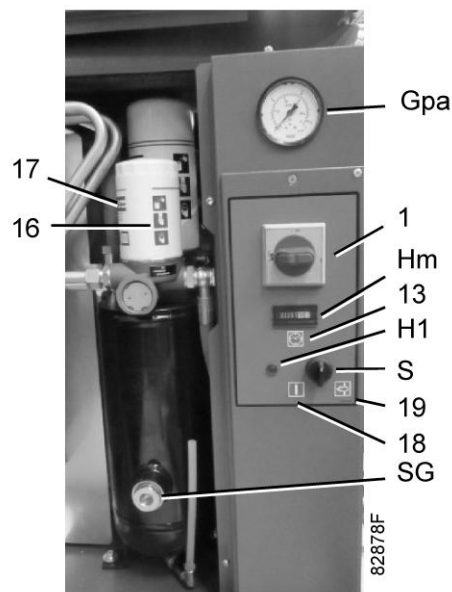

Control panel GX 7 EP

Reference	Designation	Designation
1	Main switch - emergency switch	To power the unit. Also used to stop the compressor in the event of an emergency and to reset the thermal overload of the electric motor by switching it to 0 and back to I.
3	Dryer ON/OFF switch	(On Full-Feature units)
Gpa	Pressure gauge	The pointer indicates the actual working pressure.
Hm	Hour meter	Indicates the total running time.
H1	Lamp	Lights up when the machine is operating.
S	Switch	Start/Stop switch (GX 2 EP up to GX 5 EP) Load/unload switch (GX 7 EP)

2.7 Electrical diagrams

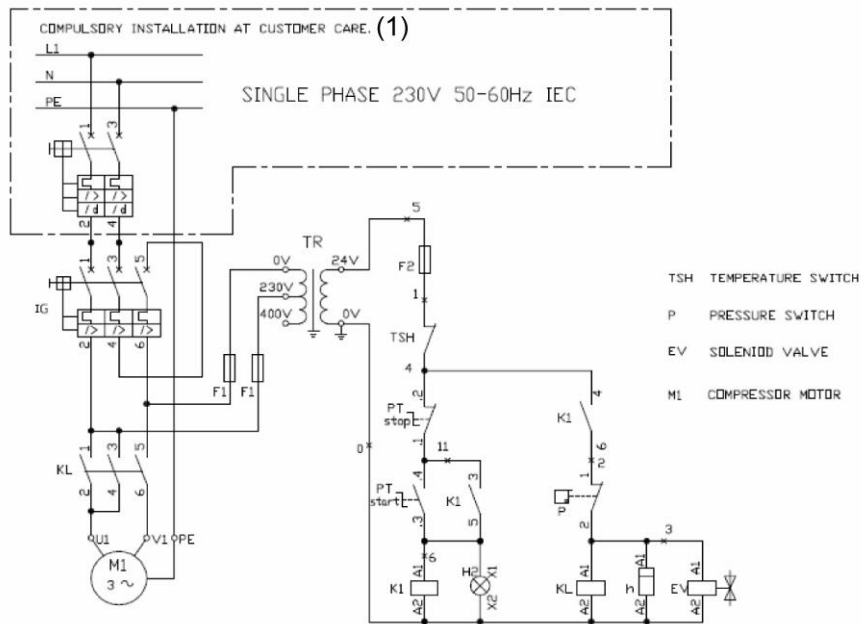

82202D

Service diagram GX 2 - IEC - 1 ph

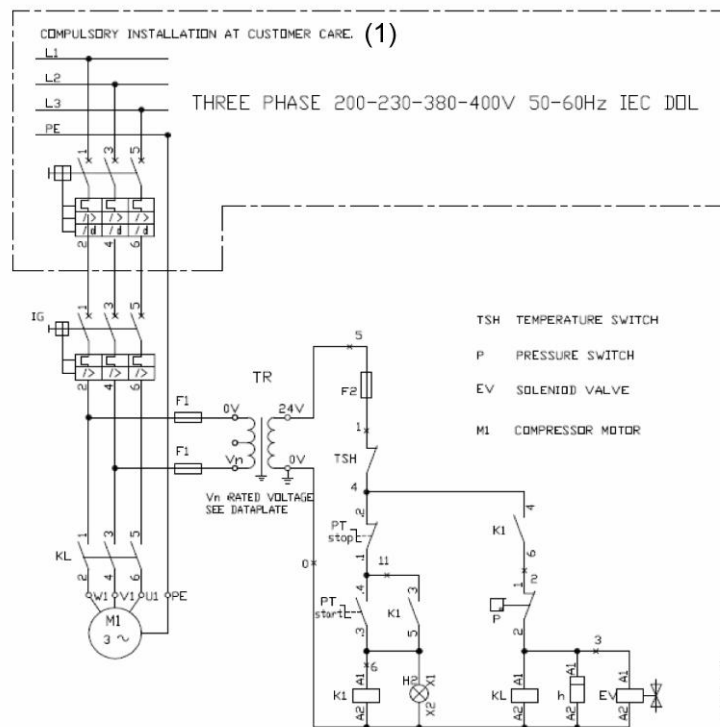

82203D

Service diagram GX 2 up to GX 5 - IEC - 3 ph DOL

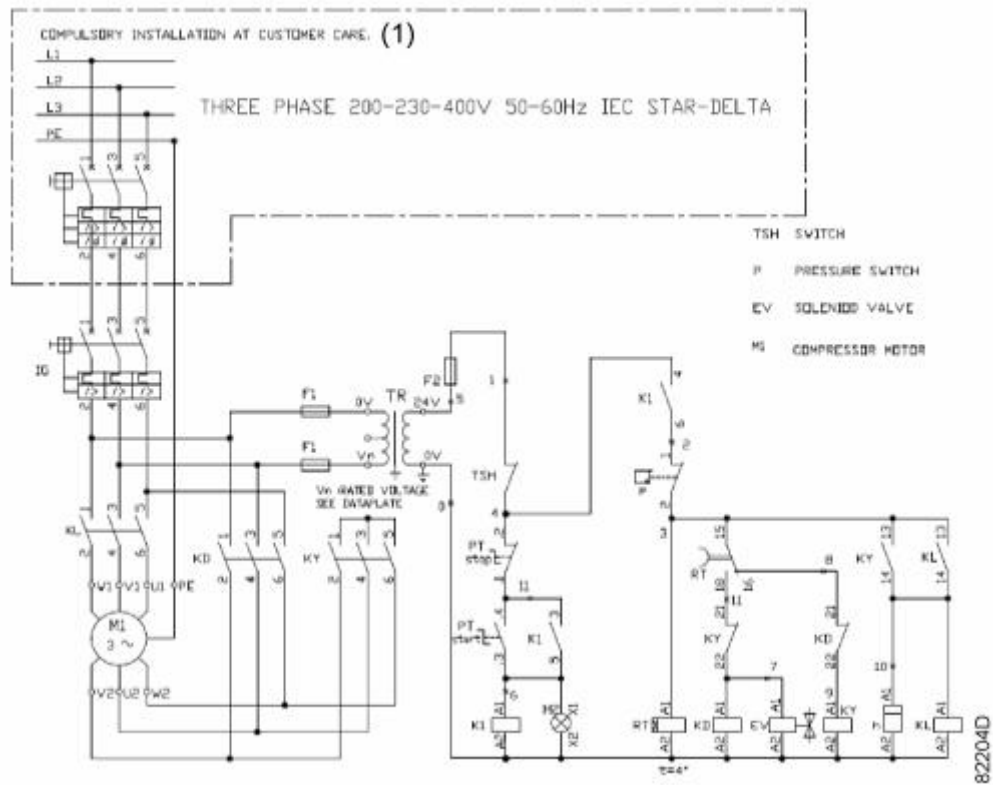

Service diagram GX 2 up to GX 5 - IEC - 3 ph Y-D

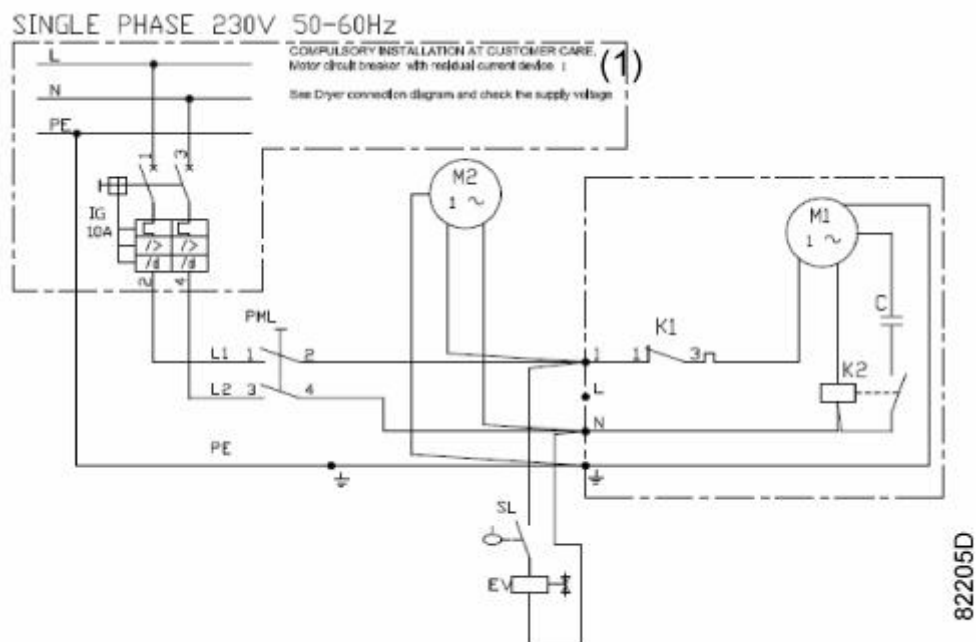

Single phase dryer - 230 V 50/60 Hz

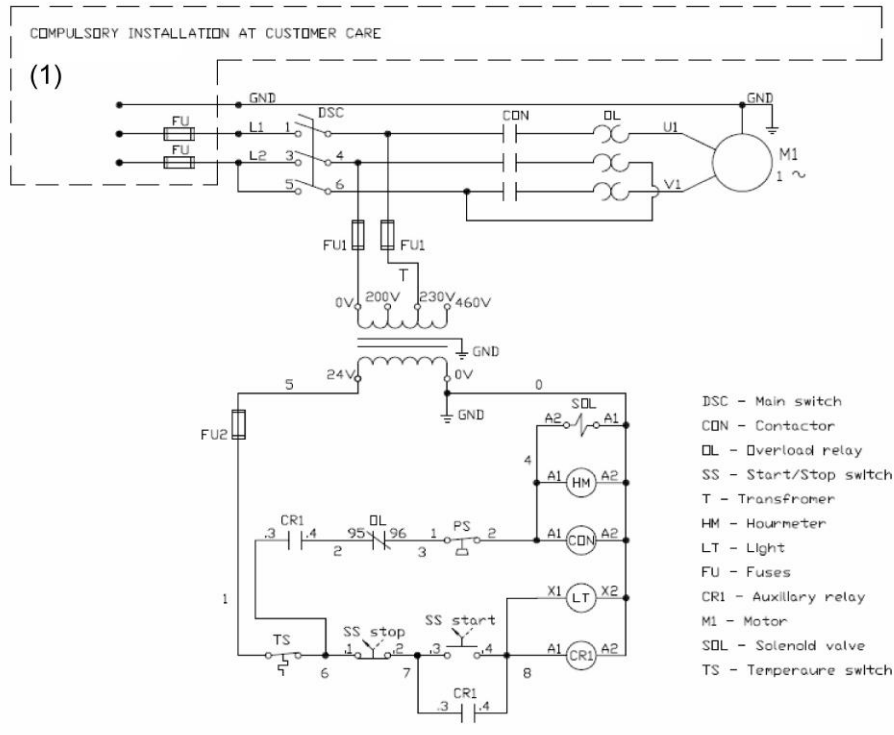

Electrical diagram GX 2 - cULus - 1 ph

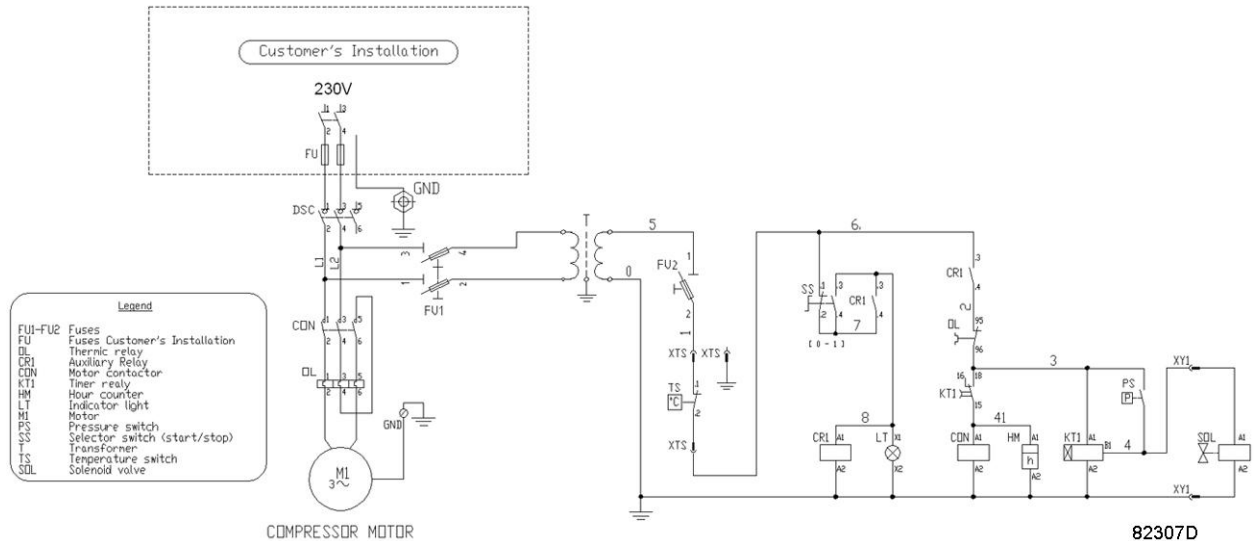

Electrical diagram GX 4 and GX 5 - cULus - 1 ph

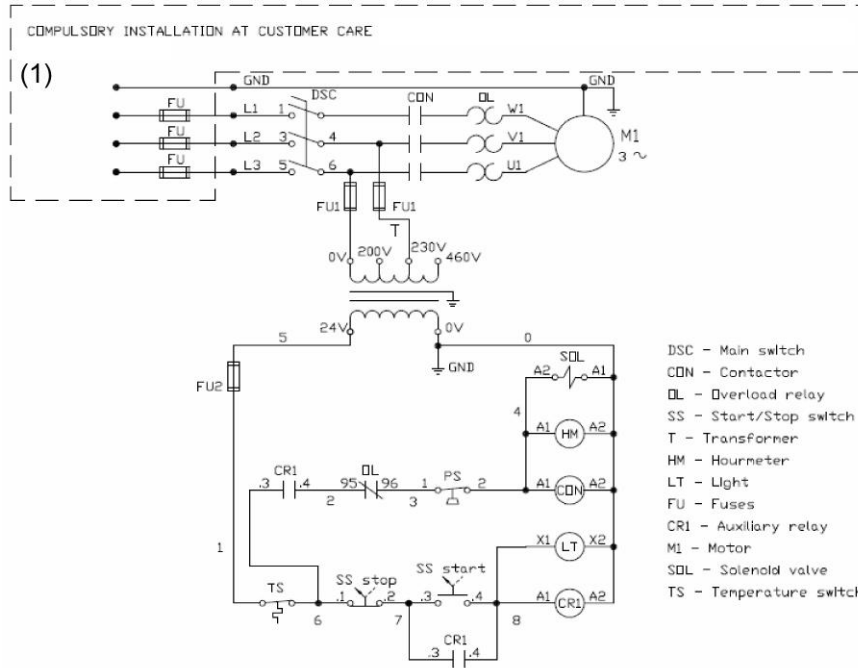

Electrical diagram GX 2 up to GX 5 - cULus - 200-208-230-460 V 3 ph

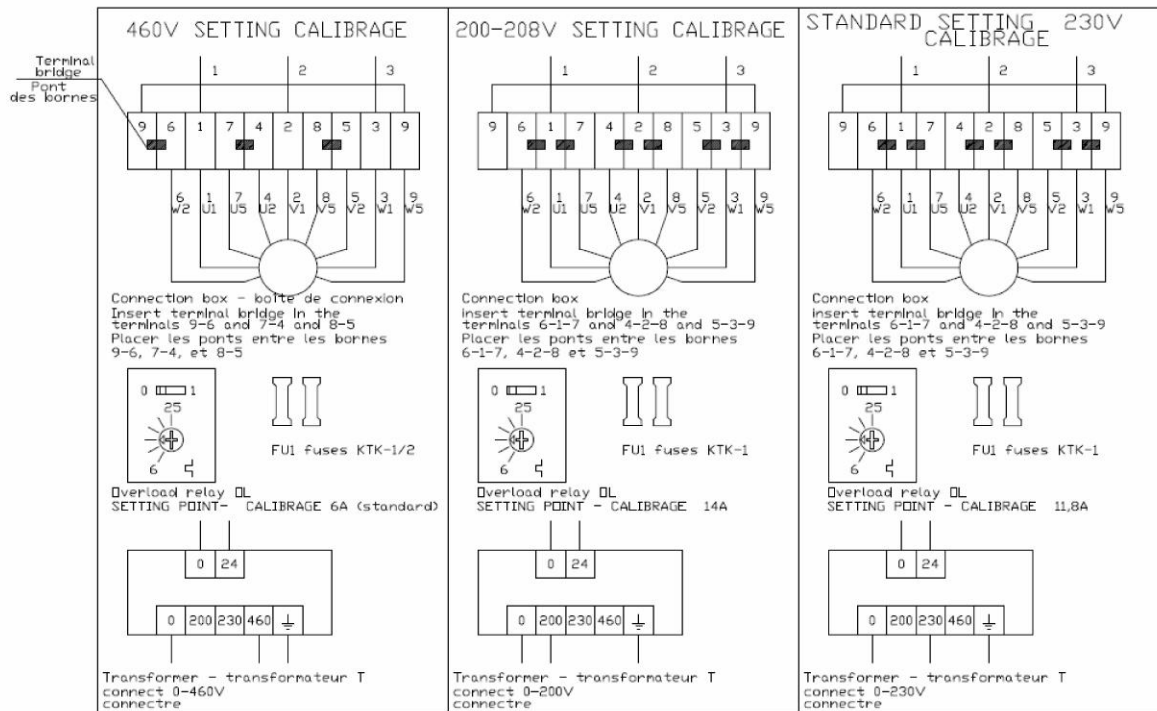

Settings GX 2 up to GX 5 for 208-230-460 V 3 ph

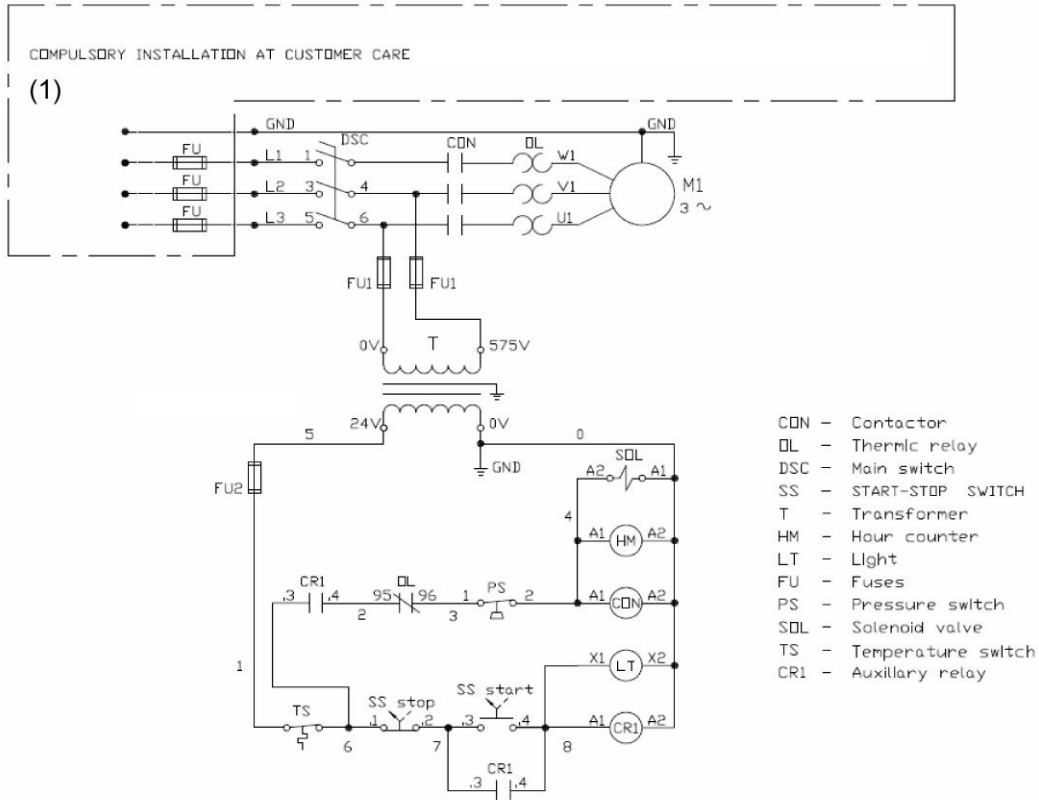

82209D

Electrical diagram 575 V 60 Hz cULus

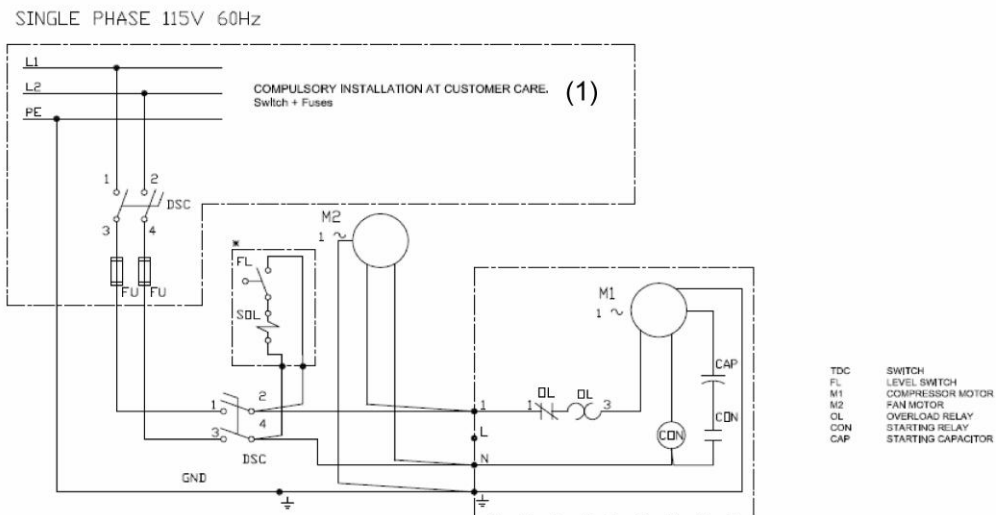

82210D

Single phase dryer - 115 V 60 Hz

Text on image

(1)	Main switch and fuses to be installed by customer.
-----	--

GX 7 EP

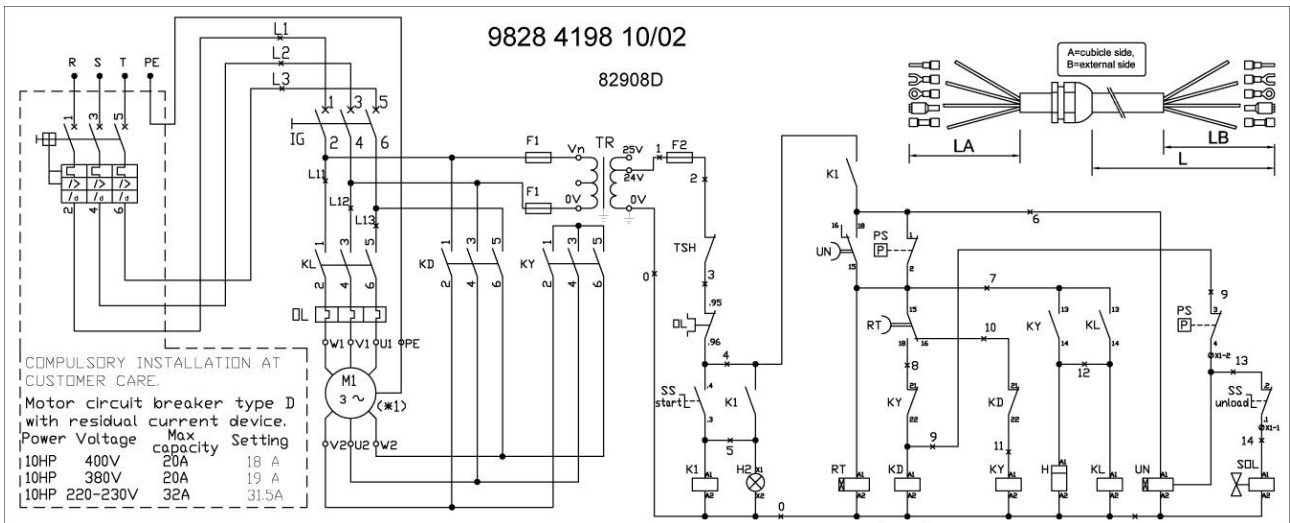

IEC units with Y-D start

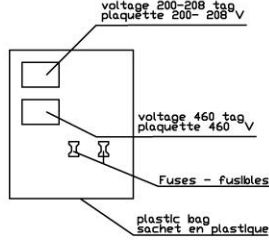
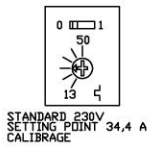

PS: PRESSURE SWITCH - PRESSOSTAT
SDL: SOLENOID VALVE - ELECTROVALVE
TS: TEMPERATURE SWITCH
XM: MOTOR'S CONNECTION TERMINALS

ATTENTION: BEFORE PUTTING INTO SERVICE, CHECK THE ROTATION SENSE OF THE MOTOR, WHICH MUST BE COUNTER-CLOCKWISE, SEEN FROM COUPLING SIDE.

ATTENTION: AVANT LA MISE EN SERVICE, VERIFIEZ LE SENSE DE ROTATION, QUI DOIT ETRE ANTIHORAIRE VU DU COTE D'ACCOUPLLEMENT.

COMPULSORY INSTALLATION AT CUSTOMER CARE - MONTAGE OBLIGATOIRE QUI DOIT ETRE FAIT PAR LE CLIENT.

FUSES - FUSIBLES
Power -puiss. Total FLA - max. A not. Fusis size -taille Fusibles
10HP 200-208V 31.6A 50A type J or RK
10HP 230V 29.9A 45A type J or RK
10HP 460V 14.7A 25A type J or RK

POWER SUPPLY LINE CABLE MUST BE PROTECTED BY A RACEWAY (DUCT) OR AN APPROVED CONDUIT SYSTEM.
PROTEGER LA LIGNE D'ALIMENTATION DU AVEC UN CONDUIT APPROUVE.

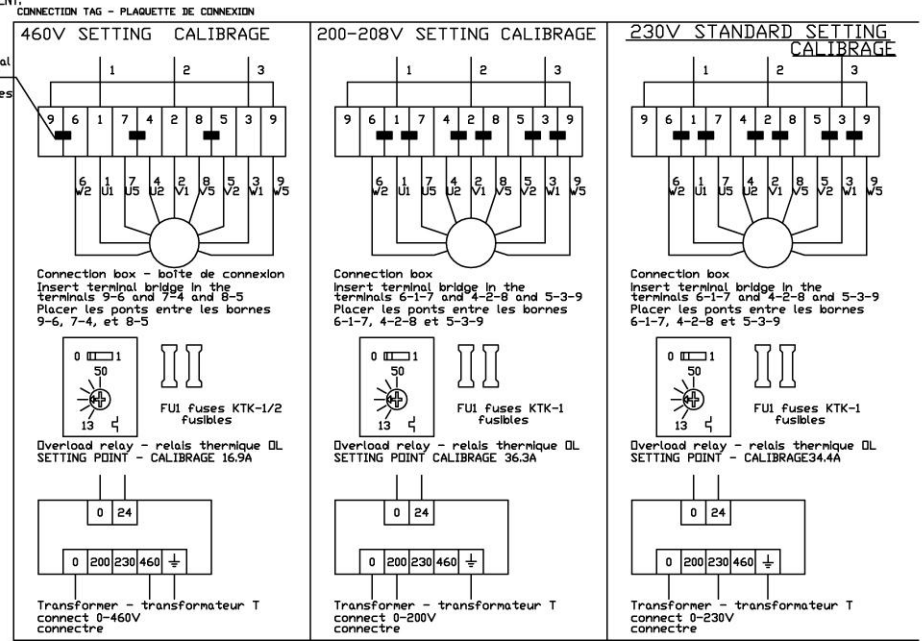
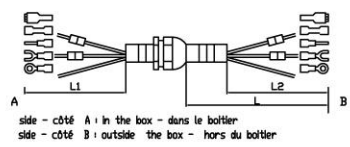
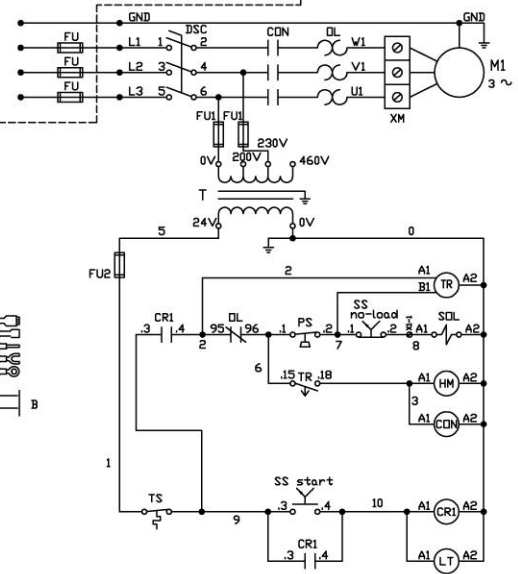

9828 4391 20/02

82909D

GX 7 EP for 208/230/460V 60 Hz DOL

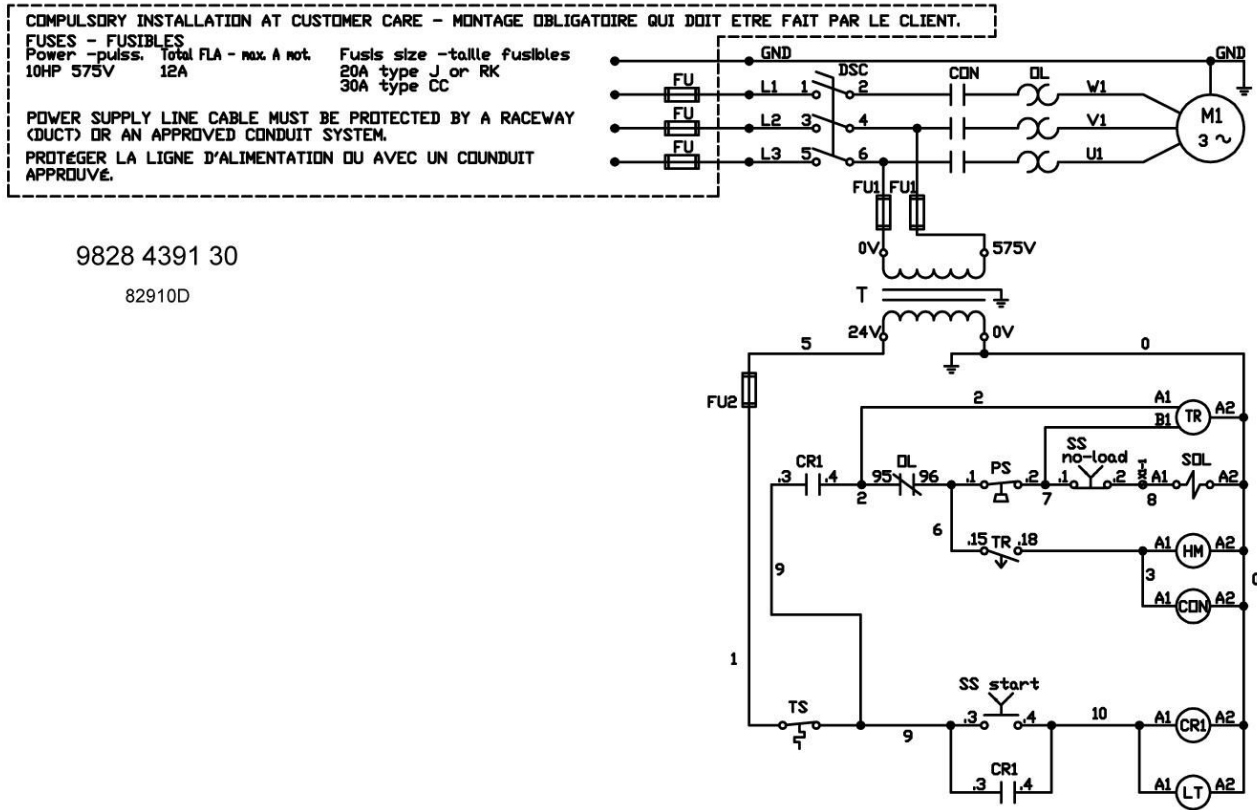
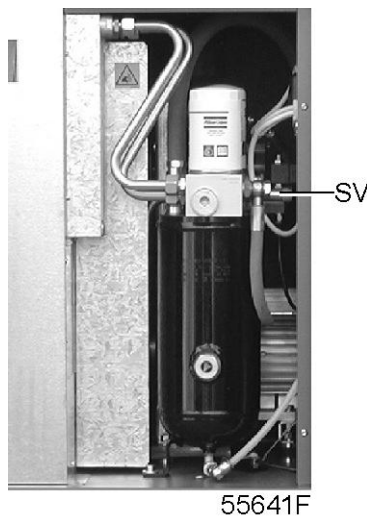

Diagram for 575 V CSA-UL

Fuses and main switch to be installed by the customer. **For full details, always consult the complete service diagram, included in the cubicle of the compressor.**

2.8 Protection of compressor



Safety valve on the compressor

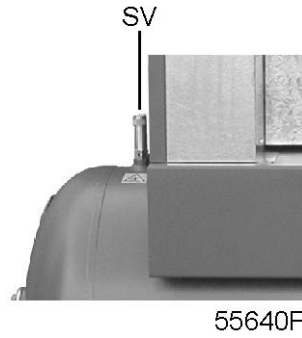

Safety valve on the air receiver (tank-mounted units)

Reference	Designation	Function
IG (IEC) OL (cULus) See also section Electrical diagrams	Motor overload relay	To shut down the compressor in case the motor current is too high.
TSH (IEC), TS (cULus) See also section Electrical diagrams	Temperature shut-down switch	To shut down the compressor if the temperature at the outlet of the compressor element is too high.
SV	Safety valve	To protect the air outlet system if the outlet pressure exceeds the opening pressure of the valve.

After tripping of the temperature protection: switch off the voltage and depressurise. Check and remedy. See [Problem solving](#). Wait a few minutes to let the machine cool down. To reset and restart, switch on the voltage and press the red reset button after unscrewing its cover: the machine will restart.

2.9 Air dryer

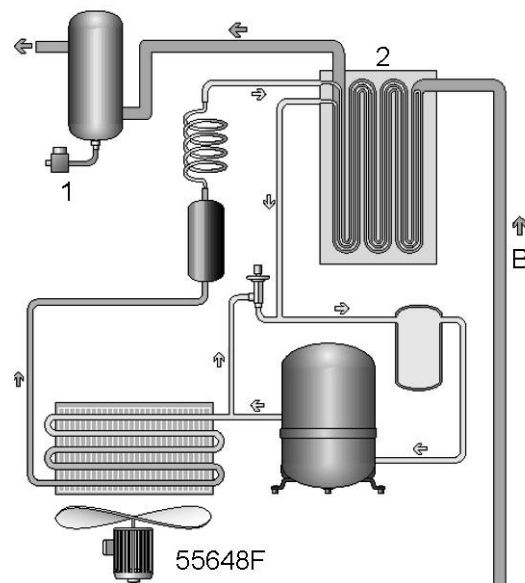

Air dryer (Full-Feature compressors)

Wet compressed air (B) enters the dryer. The air then flows through a heat exchanger (2) where refrigerant evaporates, withdrawing heat from the air. The cold air then flows through a condensate trap (1) which separates condensate from the air. The condensate is automatically drained and this is regulated by a timer. The dried air is then discharged from the dryer.

3 Installation

3.1 Installation proposal

Outdoor/altitude operation

If the compressor is installed outdoors or if the ambient temperature can be below 0°C (32°F), precautions must be taken. In this case, and also if operating at high altitude, consult Atlas Copco.

Moving/lifting

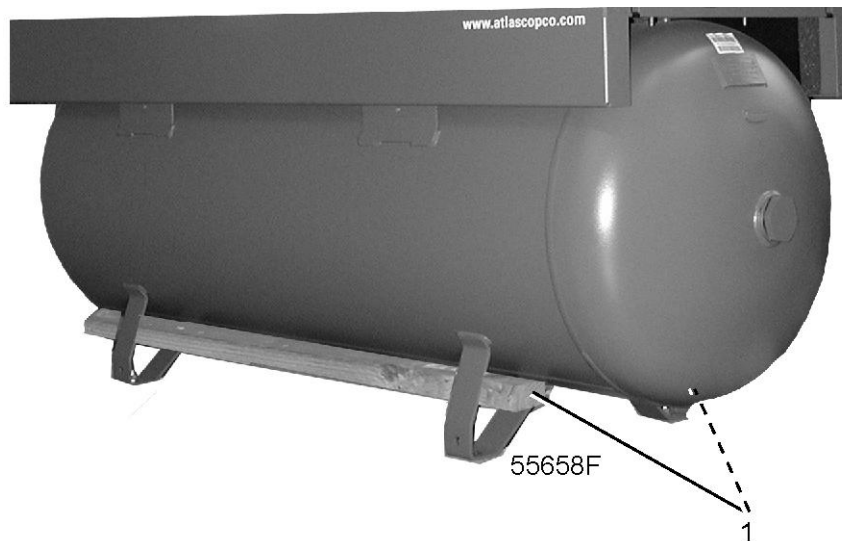

Transport by a pallet truck



To prevent a tank-mounted model from falling over during transport by a pallet truck: push the forks underneath the air receiver and place a wooden beam (1) (cross-section approx. 4 x 6 cm / 1.6 x 2.4 in) through the supports on both sides of the receiver. While holding the compressor, slowly lift the forks until the receiver is secured between the beams.

Installation proposal

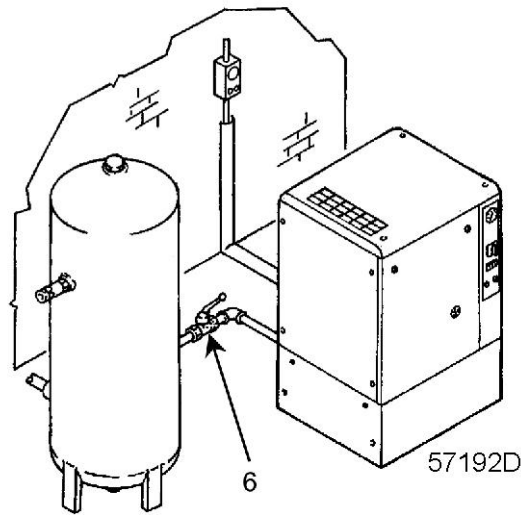

Installation proposal, Floor-mounted GX

Ref.	Description
(6)	Outlet valve

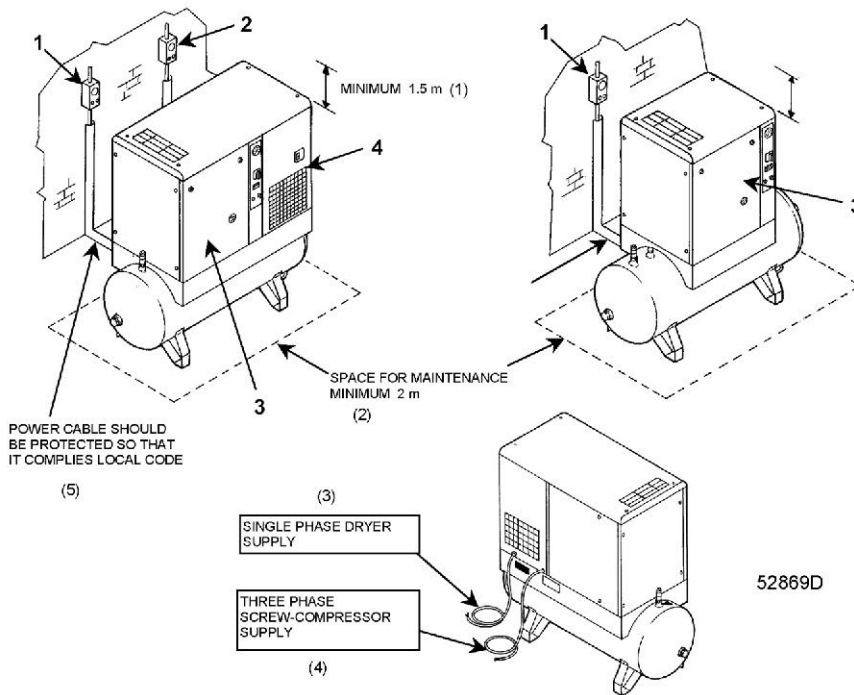

Installation proposal, tank-mounted GX

Ref.	Description/recommendation
1	Isolating switch, compressor

Ref.	Description/recommendation
2	Isolating switch, dryer
3	Front panel, compressor
4	Dryer
(1)	Minimum 1.5 m
(2)	Space for maintenance, minimum 2 m
(3)	Single-phase dryer supply
(4)	Three-phase screw compressor supply
(5)	The power cable should be protected so that it complies with local codes

Step	Action
1	Install the compressor on a solid, level floor suitable for taking the weight. The recommended minimum distance between the top of the unit and the ceiling is 1.5 m (58.5 in). The minimum distance between the wall and the back of the compressor must be 200 mm (7.8 in). Floor-mounted versions must be installed with suitable air receiver.
	The pipes between a floor-mounted compressor and air receiver are hot.
2	Position of the compressed air outlet valve. Close the valve. Connect the air net to the valve.
3	The pressure drop over the air delivery pipe can be calculated as follows: $\Delta p = (L \times 450 \times Q_c^{1.85}) / (d^5 \times P)$, with d = Inner diameter of the pipe in mm Δp = Pressure drop in bar (recommended maximum: 0.1 bar (1.5 psi)) L = Length of the pipe in m P = Absolute pressure at the compressor outlet in bar Q_c = Free air delivery of the compressor in l/s
4	Ventilation: the inlet grids and ventilation fan should be installed in such a way that any recirculation of cooling air to the compressor or dryer is avoided.
5	Lay out the condensate drain flexible from timer drain (T) as well as the flexible from condensate drain valve (4) towards a drain collector. The drain pipes to the drain collector must not dip into the water of the drain collector. See the Starting section for the location of the components.

3.2 Dimension drawings

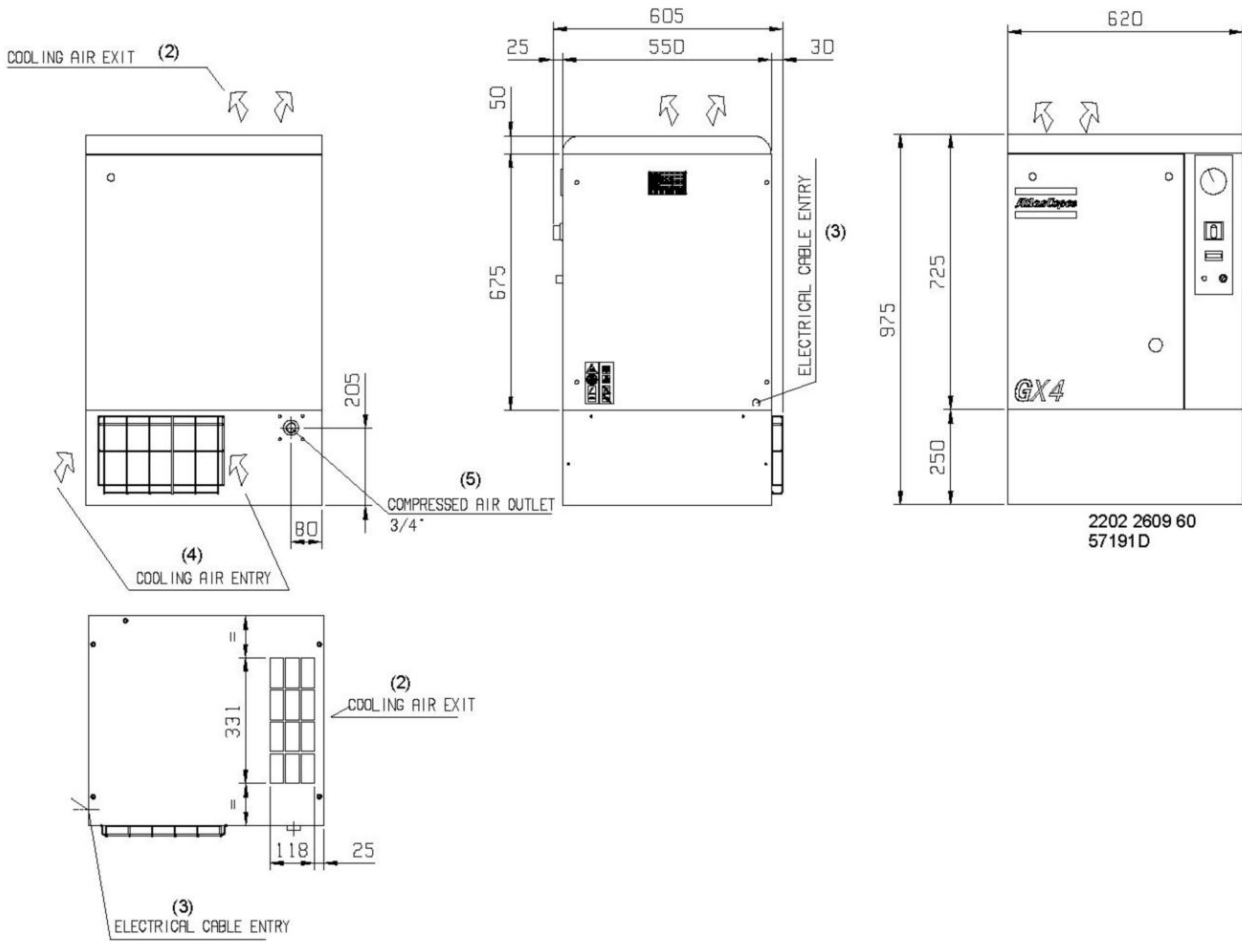

GX Pack, floor-mounted

Ref.	Designation
(2)	Cooling air outlet
(3)	Electrical cable entry
(4)	Cooling air inlet
(5)	Compressed air outlet

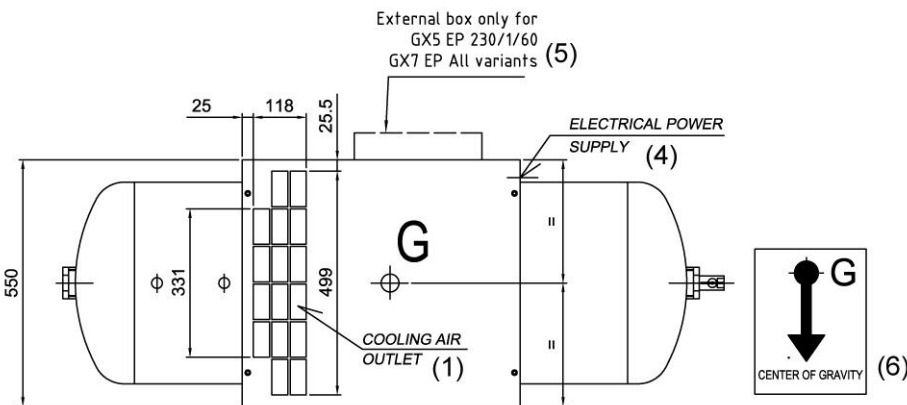
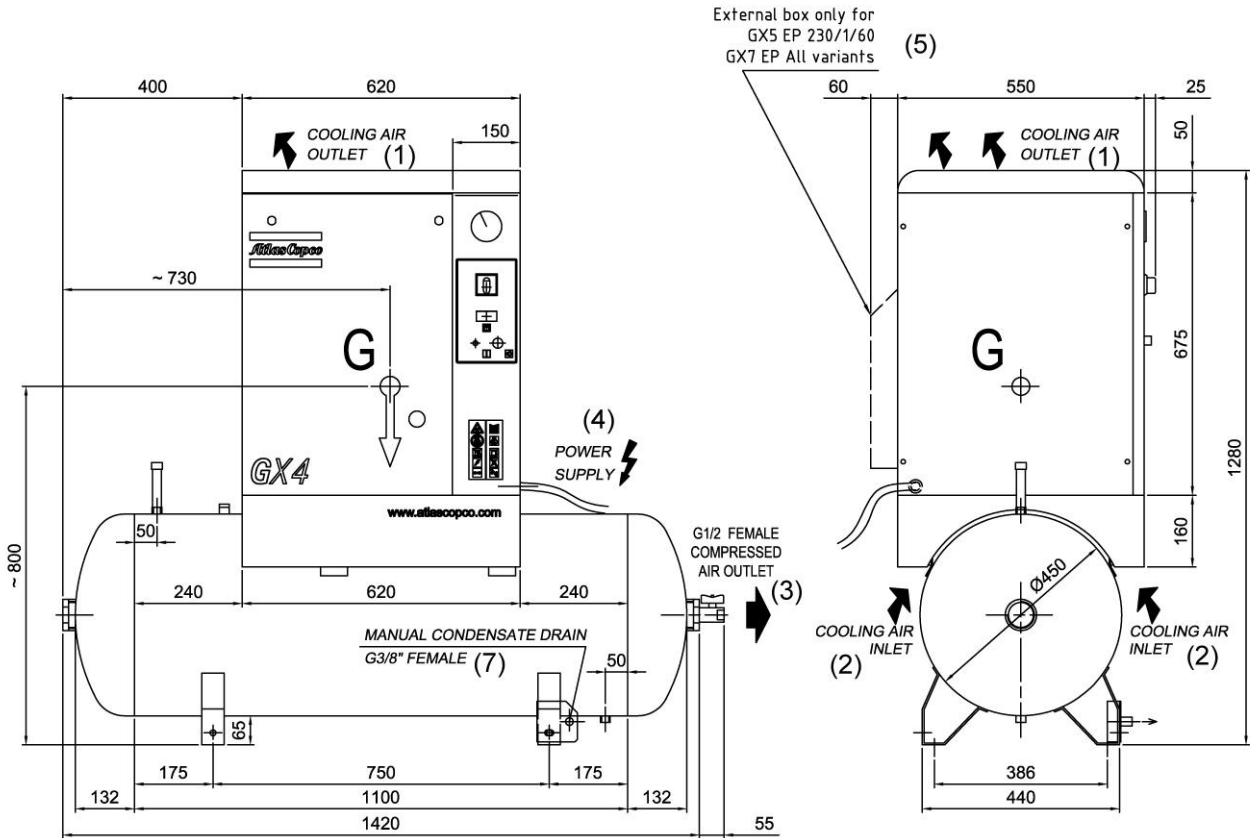

2202 2609 59/00

82881D

GX 2 up to GX 5 Pack on 200 l receiver

(1)	Cooling air outlet
(2)	Cooling air inlet
(3)	Compressed air outlet
(4)	Power supply cable
(5)	External box (only on GX 5 EP 230/1/60 and on all GX 7 EP)
(6)	Location of the centre of gravity (G)
(7)	Manual condensate drain

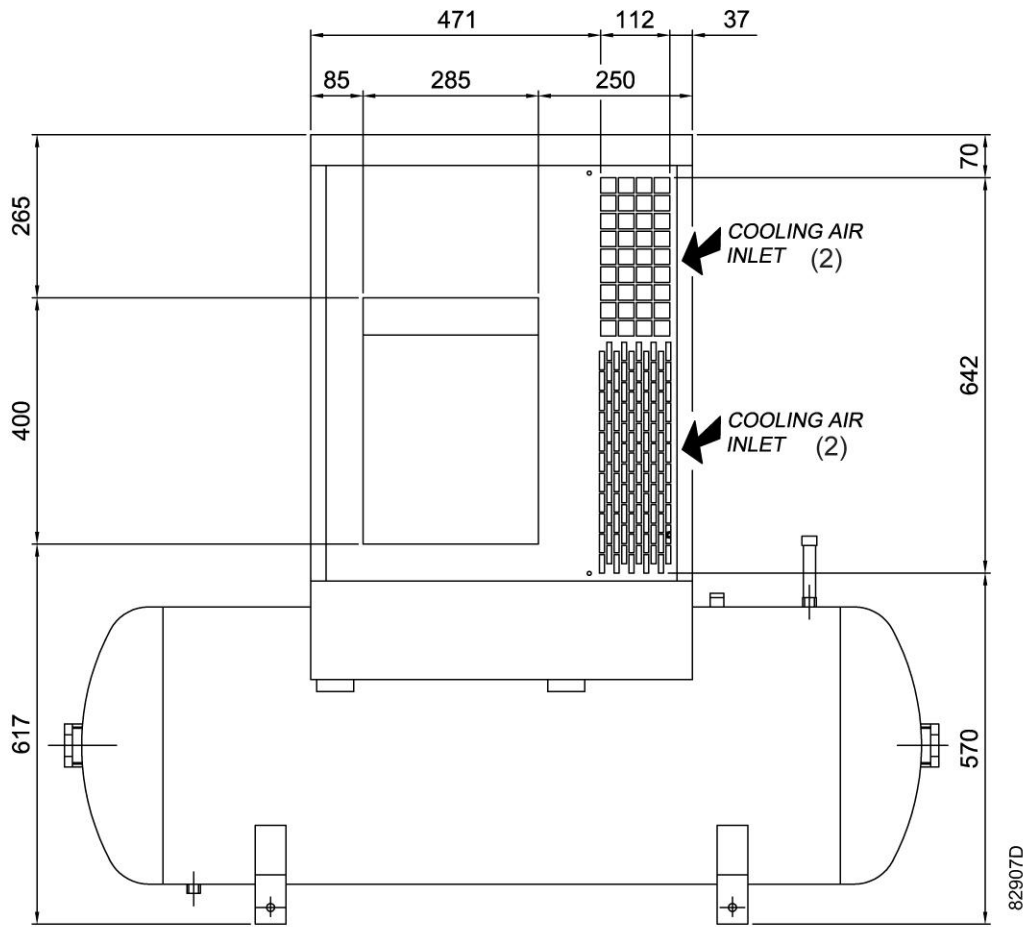

GX 7 EP Pack on 200l receiver

(2)	Cooling air inlet
-----	-------------------

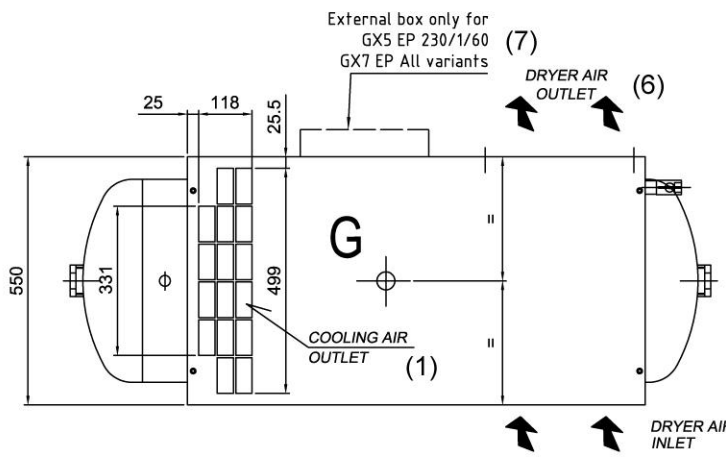
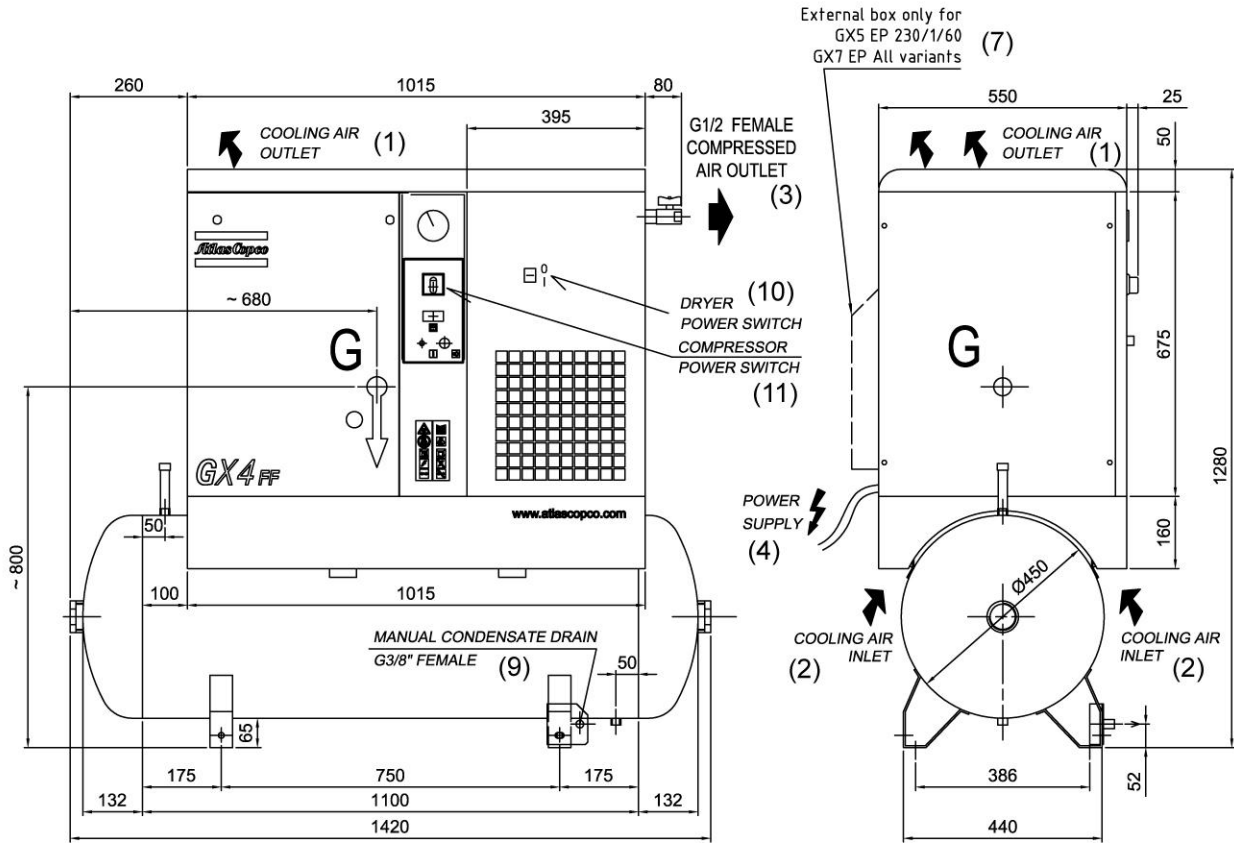

2202 2609 58/00

82880D

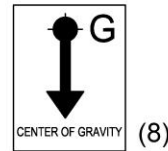

GX 2 up to GX 5 Full-Feature on 200 l receiver

(1)	Cooling air outlet
(2)	Cooling air inlet
(3)	Compressed air outlet
(4)	Power supply cable
(5)	Dryer, cooling air inlet
(6)	Dryer, cooling air outlet
(7)	External box (only on GX 5 EP 230/1/60 and on all GX 7 EP)
(8)	Location of the centre of gravity (G)

(9)	Manual condensate drain
(10)	Power switch, dryer
(11)	Power switch, compressor

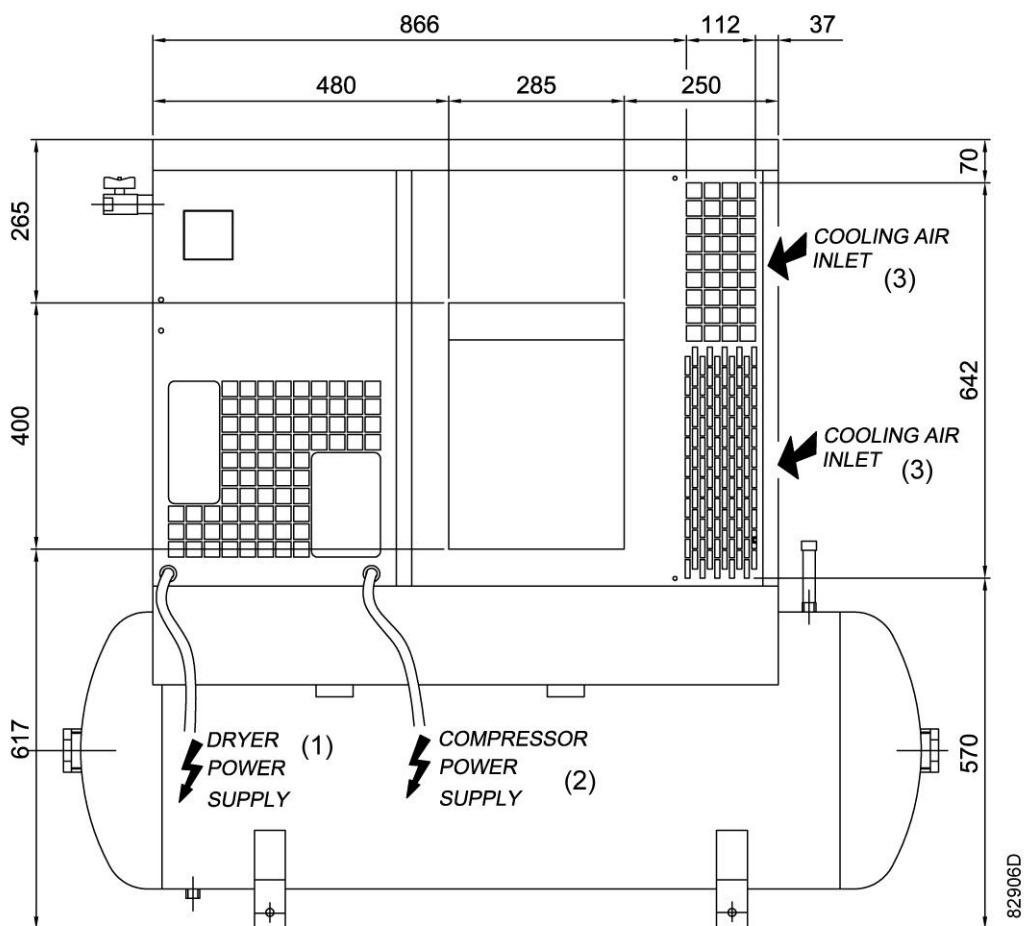

GX 7 Full-Feature on 200 l receiver

(1)	Power supply cable, dryer
(2)	Power supply cable, compressor
(3)	Cooling air inlet

3.3 Electrical connections

	Always disconnect the power supply before working on the electrical circuit!
--	--

General instructions

Step	Action
1	Ensure that the supply voltage matches the voltage on the data plate.
2	Install an isolating switch near the compressor. For Full-Feature compressors: fit an isolating switch near the dryer.
3	Fit fuses in the incoming wiring. Check the condition of all incoming wiring and make connections. See Electrical diagrams .

3.4 Pictographs

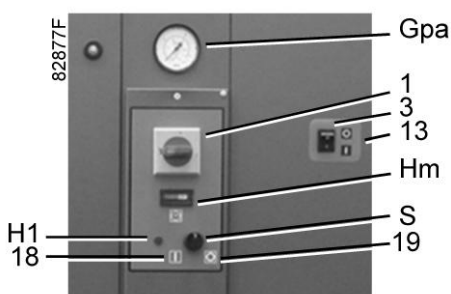
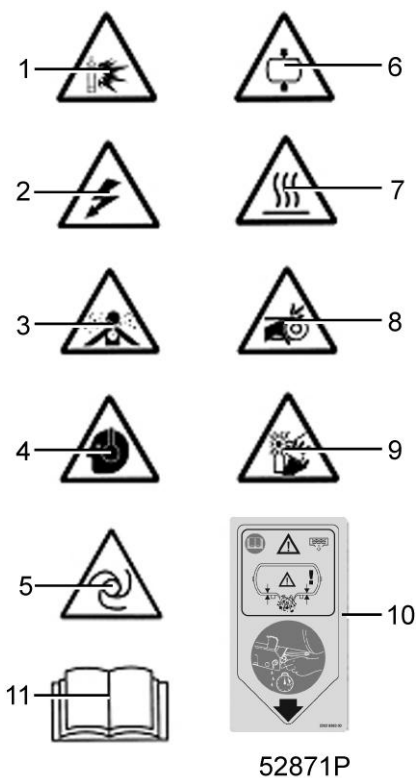

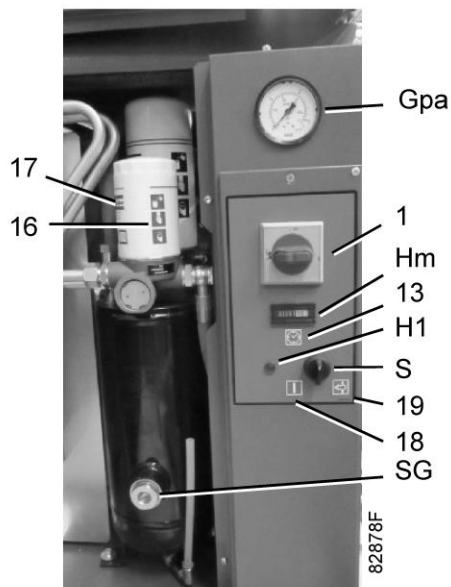

Ref.	Description
1	Warning: possible air/fluid discharge
2	Warning: voltage
3	Warning: air must not be inhaled
4	Warning: wear ear protectors
5	Warning: machine may start automatically
6	Warning: pressure
7	Warning: hot parts
8	Warning: moving parts
9	Warning: rotating fan
10	Drain condensate daily
11	Read the instruction manual
13	Hour meter
16	Read instruction manual before carrying out maintenance or repair work
17	Lightly oil gasket of oil filter, screw filter on and tighten by hand
18	Start
19	<ul style="list-style-type: none"> • GX 2 EP up to GX 5 EP: Stop • GX 7 EP: unload

4 Operating instructions

4.1 Initial start-up

Safety



The operator must apply all relevant [Safety precautions](#).

General preparation



55617F

Air outlet valve

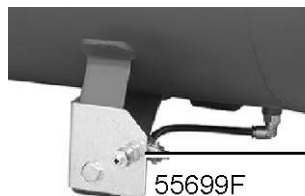

55699F

Condensate drain valve on air receiver

Step	Action
1	Consult the installation instructions (see Installation).
2	Check that the electrical connections correspond to the local codes. The installation must be earthed and protected against short circuits by fuses in all phases. An isolating switch must be installed near the compressor.
3	Fit outlet valve (2), close it and connect the air net to the valve. Connect condensate drain valve (4) of the air receiver to a drain collector. Close the valve.

Oil system

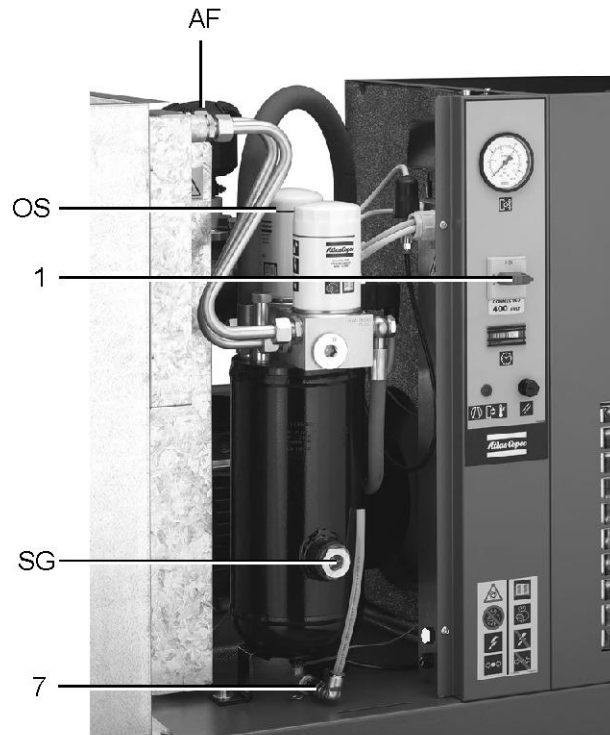

55675F

Oil level sight-glass, GX

Step	Action
	<p>If more than 3 months have passed between assembly and installation, be sure to lubricate the compressor before starting up:</p> <ul style="list-style-type: none"> • Remove the front panel. • Unscrew the fixing bolts in the top and remove the panel. • Unscrew the cover of the air filter (AF) and remove the filter element. • Open valve (7) and drain approx. 0.2 l (0.05 US gal / 0.04 Imp gal) of oil into a clean receptacle. Carefully pour this oil through the filter housing into the compressor element. • Fit the air filter and screw on the filter cover. • Refit the top and front panels.
	<p>Check the oil level. The oil level sight-glass (SG) must be above the minimum level. If the oil level is below the minimum level, top up to the middle. Do not overfill. Always use the same type of oil.</p>

Start-up



55700F

Label on the top

Step	Action
1	<p>Check that all panels of the compressor housing are fitted.</p> <p>Check that sheet (5) (explaining the procedure for checking the motor rotation direction) is affixed to the cooling air outlet of the compressor (grating on the compressor top).</p> <p>Consult Dimension drawings.</p> <p>Switch on the voltage. Start the compressor and stop it immediately.</p> <p>Check the rotation direction of the motor. If the motor rotation direction is correct, the label on the top grating will be blown upwards. If the sheet remains in place, the rotation direction is incorrect.</p> <p>If the rotation direction is incorrect, switch off the voltage, open the isolating switch and reverse two incoming electric lines.</p> <p>All electrical work should be carried out by professionally qualified people.</p>
2	<p>Start and run the compressor for a few minutes. Check that the compressor operates normally.</p>

4.2 Starting

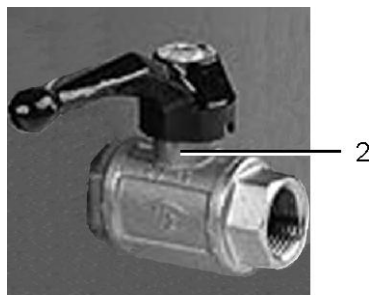

55617F

Air outlet valve



55699F

Condensate drain valve on air receiver

Starting the air dryer

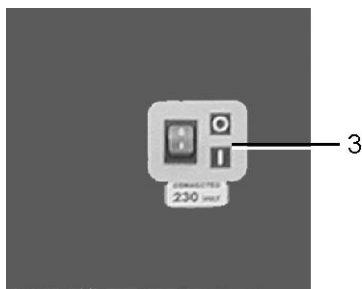

52885F

Dryer on/off switch

	<p>Switch on the voltage to the dryer and start it by moving switch (3) to position I.</p>
	<ul style="list-style-type: none"> • Switch on the dryer before starting the compressor. • The dryer must remain switched on when the compressor is operating to ensure that the air piping remains condensate-free. • If the dryer is switched off, wait at least 5 minutes before restarting the dryer; this allows for balancing of the internal pressure in the dryer.



55682F

Timer drain (rear side of the dryer)

Starting the compressor

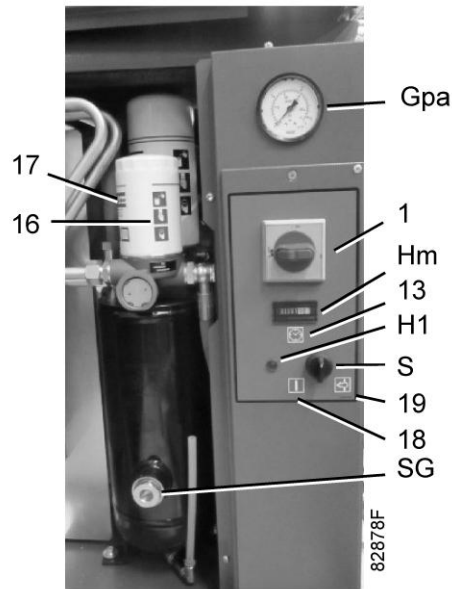

Step	Action
1	Check the oil level sight glass (SG). The oil level should be in the middle. If it is below the minimum level, top up to the middle. Do not overfill.
2	Switch on the voltage by turning switch (1) to position I
3	Open air outlet valve (2).
4	Start the unit by moving selector switch (S) to position I
5	Regularly check the working pressure (Gpa).
6	On Full-Feature compressors, regularly check that condensate is drained during operation.

4.3 Stopping

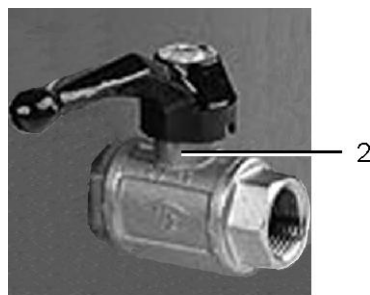

55617F

Air outlet valve

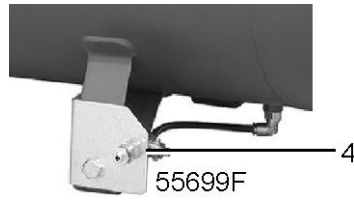

Condensate drain valve on air receiver

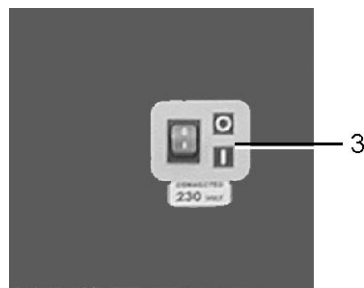
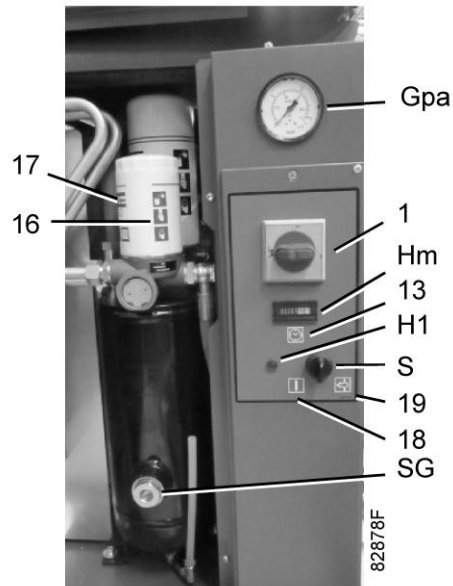
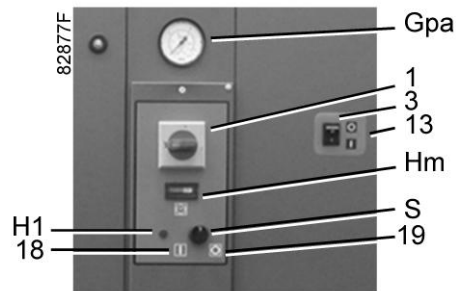

Dryer on/off switch

(82878F)

Step	Action
1	On Full-Feature units: move switch (3) of the dryer to position 0. GX 2 EP to GX 5 EP: <ul style="list-style-type: none"> • Move start/stop switch (S) to position 0. • Turn off main switch (1) GX 7 EP: <ul style="list-style-type: none"> • Move selector switch (S) to unload position. • Wait at least 30 seconds and turn off mains switch (1)
2	Close air outlet valve (2) and switch off the voltage to the compressor. On Full-Feature units: switch off the voltage to the dryer.
3	Open condensate drain valve (4) of the air receiver for a few seconds to drain any condensate and then close the valve.
	The air dryer and the air receiver remain under pressure. The integrated filter (if installed) remains pressurised. If maintenance or repair work is necessary, consult the Problem solving section for all relevant safety precautions.

4.4 Taking out of operation

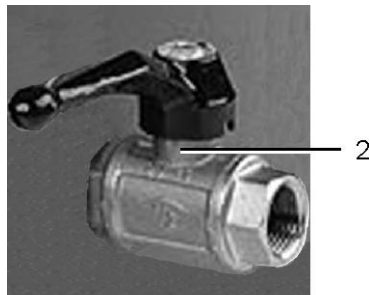

55617F

Air outlet valve

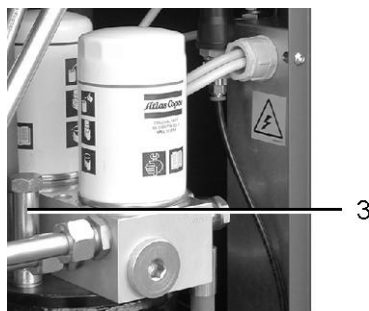

55605F

Oil filler plug

This procedure should be carried out at the end of the compressor's service life.

Step	Action
1	Stop the compressor and close the air outlet valve (2).

Step	Action
2	Switch off the voltage and disconnect the compressor from the mains.
3	Depressurise the compressor by opening plug (3) one turn. Open condensate drain valve (4) of the air receiver.
4	Shut off and depressurise the part of the air net which is connected to the outlet valve. Disconnect the compressor from the air net.
5	Drain the oil and condensate circuits.
6	Disconnect the compressor condensate outlet and valve from the condensate net.

5 Maintenance

5.1 Preventive maintenance schedule

Warning

	<p>Before carrying out any maintenance, repair work or adjustments, proceed as follows:</p> <ul style="list-style-type: none"> • Stop the compressor. • Switch off the voltage and open the isolating switch. • Close the air outlet valve and open the manual condensate drain valves. • Depressurise the compressor. <p>For detailed instructions, see the next sections. The operator must apply all relevant Safety precautions.</p>
---	---

Warranty-Product Liability

Use only authorised parts. Any damage or malfunction caused by the use of unauthorised parts is not covered by Warranty or Product Liability.

General

When servicing, replace all removed gaskets, O-rings and washers.

Intervals

Carry out maintenance at the interval which comes first. The local Atlas Copco Customer Centre may overrule the maintenance schedule, especially the service intervals, depending on the environmental and working conditions of the compressor.

The "longer interval" checks must also include the "shorter interval" checks.

Preventive maintenance schedule

Period (1)	Running hours (1)	Action
Daily	--	After stopping, drain the condensate from the air receiver . Check the oil level.
Monthly	50	For Full-Feature versions: check that condensate from the dryer is draining automatically.
"		For Floor-mounted versions: inspect the prefilter at the rear side of the compressor. Clean if necessary.
3-monthly	500 (2)	Inspect the air filter. Clean if necessary.
"	500	Check the belt tension.
"	"	For compressors with PDX filter: check the service indicator, replace the filter if necessary.
3-monthly	1000 (2)	Inspect the oil cooler; clean if necessary.

Period (1)	Running hours (1)	Action
“	“	For Full-Feature versions: inspect the condenser of the dryer; clean if necessary.
Yearly	2000 (2)	Replace the air filter.
“	2000 (3)	If Roto-Inject Fluid is used, change the oil and the oil filter.
“	2000	For compressors with PDX filter: replace the filter.
“	4000 (3)	If Roto-Xtend Duty Fluid is used, change the oil and the oil filter.
“	4000	Replace the oil separator.
“	--	Have the safety valve tested.

(1): whichever comes first.

(2): more frequently in a dusty environment

(3): The indicated oil exchange intervals are valid for standard operating conditions (see section [Reference conditions and limitations](#)) and nominal operating pressure (see section [Compressor data](#)). Exposure of the compressor to external pollutants or operation at high humidity combined with low duty cycles may require a shorter oil exchange interval. Contact Atlas Copco if in doubt.

Important

	<ul style="list-style-type: none"> • Always consult Atlas Copco if a service timer setting has to be changed. • For the change interval of oil and oil filter in extreme conditions, consult your Atlas Copco Customer Centre. • Any leakage should be attended to immediately. Damaged hoses or flexible joints must be replaced.
---	---

5.2 Drive motor

General

Keep the outside of the electric motor clean for efficient cooling. If necessary, remove dust with a brush and/or compressed air jet.

Description

The motor bearings are greased for life.

5.3 Oil specifications

	<p>Never mix oils of different brands or types as they may not be compatible and the oil mix will have inferior properties. A label, indicating the type of oil filled ex-factory, is stuck on the air receiver/oil tank.</p>
---	---

It is strongly recommended to use Atlas Copco lubricants. See section Preventive maintenance schedule for recommended oil change intervals.

For part numbers, consult the Spare Parts List.

Roto-Inject Fluid

Atlas Copco's Roto-Inject Fluid is a specially developed lubricant for use in single stage oil-injected screw compressors. Its specific composition keeps the compressor in excellent condition. Roto-Inject Fluid can be used for compressors operating at ambient temperatures between 0 °C (32 °F) and 40 °C (104 °F). If the compressor is regularly operating in ambient temperatures between 40 °C and 46 °C (115 °F), oil lifetime is reduced significantly. In such case it is recommended to use Roto-Xtend Duty Fluid.

Roto-Xtend Duty Fluid

Atlas Copco's Roto-Xtend Duty Fluid is a high quality synthetic lubricant for oil-injected screw compressors which keeps the compressor in excellent condition. Because of its excellent oxidation stability, Roto-Xtend Duty Fluid can be used for compressors operating at ambient temperatures between 0 °C (32 °F) and 46 °C (115 °F).

Roto-Foodgrade Fluid

Special oil, delivered as an option.

Atlas Copco's Roto-Foodgrade Fluid is a unique high quality synthetic lubricant, specially created for oil-injected screw compressors providing air for the food industry. This lubricant keeps the compressor in excellent condition. Roto-Foodgrade Fluid can be used for compressors operating at ambient temperatures between 0 °C (32 °F) and 40 °C (104 °F).

5.4 Oil, filter and separator change

Important



Never mix oils of different brands or types. A label, indicating the type of oil filled ex-factory, is stuck on the air receiver/oil tank.
Always drain the compressor oil at all drain points. Used oil left in the compressor can shorten the lifetime of the new oil.
If the compressor is exposed to external pollutants, is being used at high temperatures (oil temperature above 90 °C / 194 °F) or is being used under severe conditions, it is advisable to change the oil more frequently. Consult Atlas Copco.

GX 2 up to GX 5

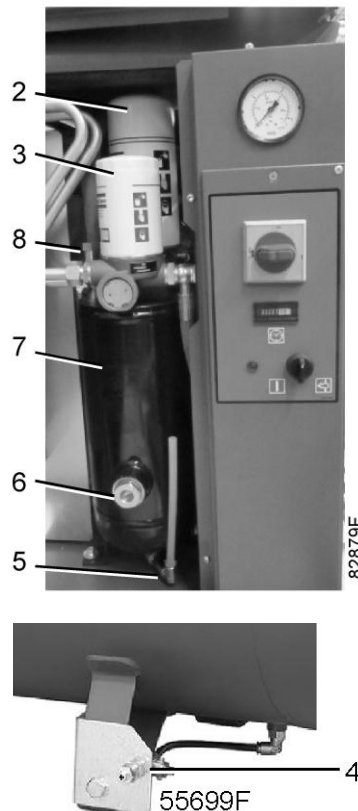

Step	Action
1	Run the compressor until warm. Stop the compressor, close the air outlet valve and switch off the voltage.
2	Remove the front and top panels.
3	Depressurise the compressor by unscrewing filler plug (8) one turn to permit any pressure in the system to escape.
4	Depressurise the air receiver by opening drain valve (4).
5	Drain the oil by opening drain valve (5). Close the valve after draining. Deliver the spent oil to the local oil collection service.
6	Remove oil filter (3) and separator (2). Clean the seats on the manifold.
7	Oil the gaskets of the new filter and separator and screw them into place. Tighten firmly by hand.
8	Remove filler plug (8) and fill oil tank (7) with oil until the level reaches the middle of sight-glass (6). Ensure no dirt gets into the system. Refit and tighten filler plug (8).
9	Unscrew the air filter cover (1), remove the filter element and carefully pour approx. 0.1 l (0.03 US gal / 0.02 Imp gal) of oil into the compressor element. Do not overfill.
10	Re-assemble the inlet filter
11	Fit the bodywork panels.
12	Close drain valve (4) of the air receiver.
13	Run the compressor for a few minutes. Check the oil level.

5.5 Storage after installation

If the compressor is stored without running from time to time, consult Atlas Copco as protective measures may be necessary.

5.6 Service kits

Service kits

For overhauling and for preventive maintenance, a wide range of service kits is available. Service kits comprise all parts required for servicing the component and offer the benefits of genuine Atlas Copco parts while keeping the maintenance budget low.

Also a full range of extensively tested lubricants, suitable for your specific needs is available to keep the compressor in excellent condition.

Consult the Spare Parts List for part numbers.

6 Adjustments and servicing procedures

6.1 Air filter

Changing the air filter

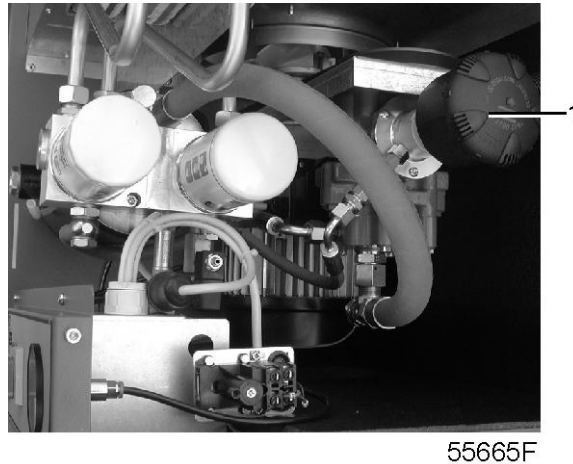

Air filter (1)

Procedure:

Step	Action
1	Stop the compressor, close the air outlet valve and switch off the voltage.
2	Remove the front panel and the top panel of the compressor housing.
3	Unscrew the filter cover (1) and remove the filter element. Discard the air filter element.
4	Fit the new element and screw on the filter cover.
5	Refit the top and front panels.

6.2 Coolers

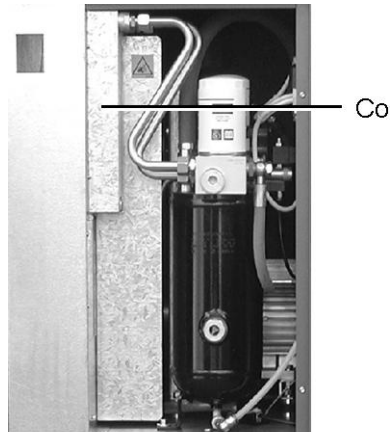

55683F

Oil cooler

Step	Action
1	Keep oil cooler (Co) clean to maintain the cooling efficiency.
2	Stop the compressor, close the air outlet valve and switch off the voltage. Remove any dirt from the cooler with a fibre brush. Never use a wire brush or metal objects. Then clean using an air jet.

6.3 Safety valve



55699F

Condensate drain valve on air receiver

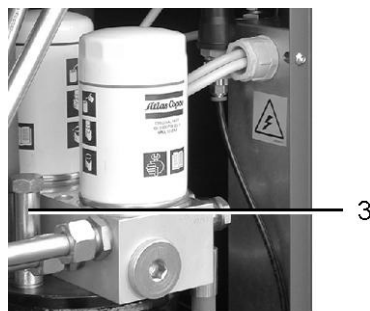

55605F

Oil filler plug

Testing

The valve can be tested on a separate compressed air line.

Before removing the valve, stop the compressor (see section [Stopping](#)).

On a Full-Feature unit also stop the dryer.

Close the air outlet valve, switch off the voltage, open drain valves (4) (if applicable) and unscrew filler plug (3) one turn to permit any pressure in the system to escape.

	If the valve does not open at the set pressure stamped on the valve, replace the valve. No adjustments are allowed. Never run the compressor without a safety valve.
--	--

6.4 Belt set exchange and tensioning

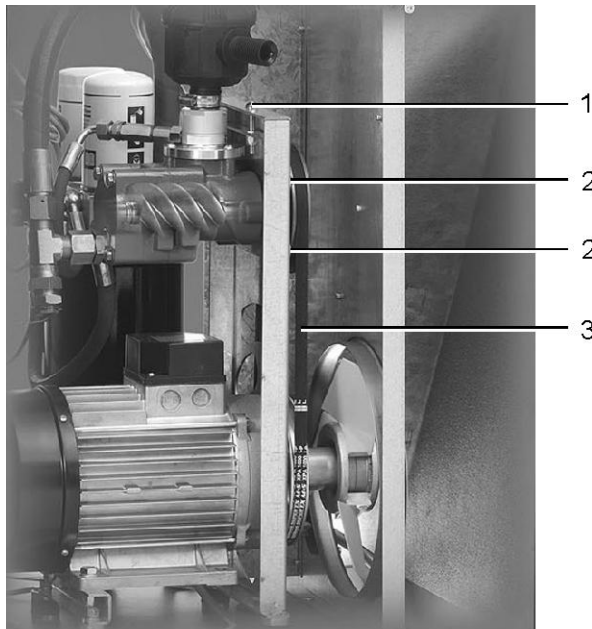

52880F

	Read the warning in the Preventive maintenance schedule section.
--	--

Belt tensioning procedure

Step	Action
1	Stop the compressor, close the air outlet valve and switch off the voltage. For Full-Feature versions: also stop the dryer.
2	Remove the front panel of the compressor housing.
3	Remove the side, back and top panels of the compressor housing.
4	Loosen the 4 bolts (2) by one turn.
5	Adjust the belt tension by turning tensioning nut (1).

Step	Action
6	The tension is correct when a force of 50 N (11.25 lbf) applied at the midpoint of the belt causes a deflection of 6 mm (0.23 in).
7	Retighten bolts (2).
8	Refit the bodywork panels.

Belt replacement procedure

Step	Action
1	Stop the compressor, close the air outlet valve and switch off the voltage. For Full-Feature versions: also stop the dryer.
2	Remove the front panel of the compressor housing.
3	Remove the side, back and top panels of the compressor housing.
4	Loosen the 4 bolts (2) by one turn.
5	Release the belt tension by loosening tensioning nut (1).
6	Remove the fan cowl.
7	Remove the belt via the fan cowl opening. Install the new belt via the same opening.
8	Tension belt (3) as described above.
9	Re-assemble the fan cowl.
10	Refit the bodywork panels.
11	Check the belt tension after 50 running hours.

7 Problem solving

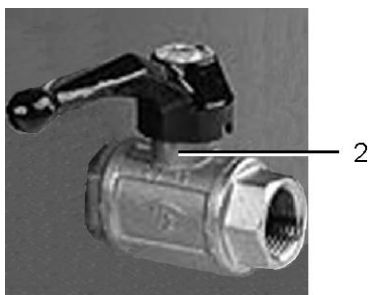

55617F

Air outlet valve

Dryer on/off switch

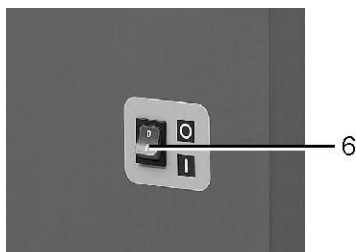

55604F

GX Full-Feature

Attention

	<p>Use only authorised parts. Any damage or malfunction caused by the use of unauthorised parts is not covered by Warranty or Product Liability. Apply all relevant Safety precautions during maintenance or repair.</p>
	<p>GX 2 EP to GX 5 EP:</p> <ul style="list-style-type: none"> • Move start/stop switch (S) to position 0. • Turn off main switch (1) <p>GX 7 EP:</p> <ul style="list-style-type: none"> • Move selector switch (S) to unload position. • Wait at least 30 seconds and turn off mains switch (1) <p>Move dryer on/off switch (6) to position 0. Wait until the compressor has stopped and switch off the voltage. See the Stopping section. Open the isolating switch to prevent an accidental start. Close air outlet valve (2) and depressurise the compressor by opening the oil filler plug (3) one turn. Open manual condensate drain valves (4 and/or 5).</p>
	<p>The air outlet valve (2) can be locked during maintenance or repair as follows:</p> <ul style="list-style-type: none"> • Close the valve. • Remove the screw fixing the handle • Lift the handle and turn it until the slot of the handle fits over the blocking edge on the valve body. • Fit the screw.

Faults and remedies

For all references given hereafter, see [Air flow diagram](#), [Initial start-up](#) or [Regulating system](#).

Compressor

	Condition	Fault	Remedy
1	The machine does not start	No power	Check power supply
		Fuse (F1) blown	Replace fuse
		The main motor thermal protection has tripped	Check and let motor cool down; to reset/restart, move compressor start/stop switch to 0, then to I
2	The machine does not start, high oil temperature lamp is on (temperature switch tripped)	Oil cooler is dirty	Clean cooler
		Ambient temperature too high	Improve ventilation in compressor room
		Oil level too low	Top up oil tank
3	The compressor does not reach working pressure	Blow-off solenoid valve (Y1) remains open	Check; replace valve if necessary
4	Excess oil consumption	Oil separator (OS) clogged	Replace oil separator
		Oil level too high	Drain to correct level

Air dryer

	Condition	Fault	Remedy
1	No compressed air passes through the dryer	Pipes are frozen inside	Hot-gas by-pass valve malfunctioning; consult Atlas Copco

	Condition	Fault	Remedy
2	Condensate in the piping	Insufficient condensate drain	Check the operation of timer (T)
		The dryer is working outside its rating	Check room temperature - air temperature at dryer. Clean the condenser and check operation of fan
3	The compressor head is very hot (above 55°C / 131°F) - motor overload	The dryer is working outside its rating	Check room temperature - air temperature at dryer. Clean the condenser and check operation of fan
		Insufficient refrigerant in dryer	Have system checked for leaks or refilled
4	The motor hums and does not start	Line voltage too low	Check power supply
		The machine was switched off and on again too rapidly (not enough time for the pressure equalization)	Wait a few minutes before starting the machine again

8 Technical data

8.1 Readings on control panel

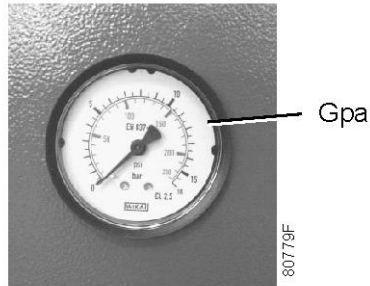

Pressure gauge

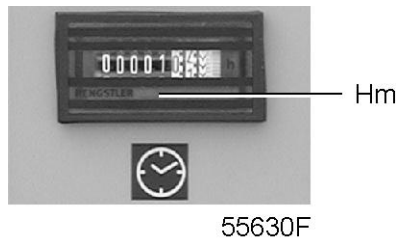

Hourmeter



The readings mentioned below are valid under the reference conditions (see [Reference conditions and limitations](#)).

Ref.	Name
Gpa	Air outlet pressure Reading: Modulates between preset unloading/stopping pressure and loading pressure
Hm	Hour meter Reading: Total running time

8.2 Electric cable size

Attention



Local regulations remain applicable if they are stricter than the values proposed below. The voltage drop must not exceed 5 % of the nominal voltage. It may be necessary to use cables of a larger size than those stated to comply with this requirement.

		GX 2	GX 3	GX 4	GX 5	GX 7
Frequency (Hz)	Voltage (V)	Cable size	Cable size	Cable size	Cable size	Cable size
IEC						
50	200 - 3	2.5 mm ²	-	-	6 mm ²	
50	230 - 1	2.5mm ²	-	-	-	
50	230 - 3	2.5 mm ²	2.5 mm ²	4 mm ²	4 mm ²	6 mm ²
50	400 - 3	1 mm ²	1 mm ²	1.5 mm ²	1.5 mm ²	4 mm ²
60	200 - 3	2.5 mm ²	-	4 mm ²	6 mm ²	
60	230 - 1	2.5 mm ²	-	-	-	
60	230 - 3	2.5 mm ²	2.5 mm ²	4 mm ²	4 mm ²	
60	380 - 3	1 mm ²	1 mm ²	1.5 mm ²	1.5 mm ²	4 mm ²
CSA/UL						
60	230 - 1	AWG10	-	AWG8	AWG6	
60	208-230-460	AWG12	-	AWG10	AWG10	AWG8
60	575	AWG14	-	AWG14	AWG14	AWG14

8.3 Settings for overload relay and fuses

GX 2 and GX 3

Frequency (Hz)	Voltage (V)	Overload relay (IG), GX 2 (A)	Circuit breaker, GX 2 (A) (see note 1)		Overload relay (IG), GX 3 (A)	Circuit breaker, GX 3 (A) (see note 1)		Circuit breaker, dryer supply (A) (see note 1)	
			Max. capacity	Setting		Max capacity	Setting	Max capacity	Setting
IEC	DOL								
50	200	15	16	15	-	-	-	6.3	2
50	230	11.8	16	14	16	16	16	6.3	2
50	230, 1-ph	20	20	20	-	-	-	6.3	2
50	400	8	10	8	10	10	10	6.3	2
60	200	15	16	15	-	-	-	6.3	2
60	380	8	10	8	10	10	10	6.3	2

Frequency (Hz)	Voltage (V)	Overload relay (OL), GX 2 (A)	Main fuses, compressor supply, GX 2 (A)		Overload relay (OL), GX 3 (A)	Main fuses, compressor supply, GX 3 (A)		Main fuses, dryer supply (A)	
			Type J or RK	Type CC		Type J or RK	Type CC	Type J or RK	Type CC
cULus	DOL								
60	200-208	14	20	-	-	-	-	4.5	8
60	230	11.8	20	-	-	-	-	4.5	8
60	230, 1-ph	21.5	30	-	-	-	-	4.5	8
60	460	6	10	15	-	-	-	4.5	8

60	575	5	8	12	-	-	-	4.5	8
----	-----	---	---	----	---	---	---	-----	---

(1): Motor circuit breaker with residual current device type D

GX 4 and GX 5

Frequency (Hz)	Voltage (V)	Overload relay (IG), GX 4 (A)	Circuit breaker, GX 4 (A) (see note 1)		Overload relay (IG), GX 5 (A)	Circuit breaker, GX 5 (A) (see note 1)		Circuit breaker, dryer supply (A) (see note 1)	
			Max. capacity	Setting		Max capacity	Setting	Max capacity	Setting
IEC	DOL								
50	230	19	20	20	-	-	-	6.3	2
50	400	11	16	11	-	-	-	6.3	2
60	200	19	20	19	-	-	-	6.3	2
60	380	11	16	11	13.5	16	13.5	6.3	2
IEC	Y-D								
50	200	-	-	-	25	32	25	6.3	2
50	230	19	20	20	23.5	25	23.5	6.3	2
50	400	11	16	11	13.5	16	13.5	6.3	2
60	200	-	-	-	25	32	25	6.3	2

Frequency (Hz)	Voltage (V)	Overload relay (OL), GX 4 (A)	Main fuses, compressor supply, GX 4 (A)		Overload relay (OL), GX 5 (A)	Main fuses, compressor supply, GX 5 (A)		Main fuses, dryer supply (A)	
			Type J or RK	Type CC		Type J or RK	Type CC	Type J or RK	Type CC
cULus	DOL								
60	200-208	21.2	30	-	24.7	40	-	4.5	8
60	230	18.2	30	-	22.5	40	-	4.5	8
60	230, 1-ph	30.8	60	-	41	60	-	4.5	8
60	460	9.1	12	25	11.4	15	25	4.5	8
60	575	7.5	10	15	9.5	12	20	4.5	8

(1): Motor circuit breaker with residual current device type D

GX 7

Frequency (Hz)	Voltage (V)	Overload relay (IG), GX 7 (A)	Circuit breaker, GX 7 (A) (see note 1)		Circuit breaker, dryer supply (A) (see note 1)	
			Max. capacity	Setting	Max capacity	Setting
IEC	Y-D					
50	230	19.1	32	31.5	6.3	2
50	400	11	20	18	6.3	2
60	380	11	20	19	6.3	2

Frequency (Hz)	Voltage (V)	Overload relay (OL), GX 7 (A)	Main fuses, compressor supply, GX 7 (A)		Main fuses, dryer supply (A)	
			Type J or RK	Type CC	Type J or RK	Type CC
cULus	DOL					
60	200-208	36.3	50	-	4.5	8
60	230	34.4	45	-	4.5	8
60	460	16.9	25	25	4.5	8
60	575	13.8	20	15	4.5	8

(1): Motor circuit breaker with residual current device type D

8.4 Reference conditions and limitations

Reference conditions

Air inlet pressure (absolute)	bar	1
Air inlet pressure (absolute)	psi	14.5
Air inlet temperature	°C	20
Air inlet temperature	°F	68
Relative humidity	%	0
Working pressure	bar(e)	See Compressor data
Working pressure	psi	See Compressor data

Limitations

Maximum working pressure	bar(e)	See Compressor data
Maximum working pressure	psig	See Compressor data
Minimum working pressure	bar(e)	4
Minimum working pressure	psig	58
Maximum air inlet temperature	°C	46
Maximum air inlet temperature	°F	115
Minimum ambient temperature	°C	0
Minimum ambient temperature	°F	32

8.5 Compressor data

	All data specified below apply under reference conditions, see section Reference conditions and limitations..
---	---

50 Hz 10 bar

Compressor type		GX 2	GX 3	GX 4	GX 5	GX 7
Frequency	Hz	50	50	50	50	50
Maximum (unloading) pressure, Pack	bar(e)	10	10	10	10	10
Maximum (unloading) pressure, Pack	psig	145	145	145	145	145
Maximum (unloading) pressure, Full-Feature	bar(e)	9.75	9.75	9.75	9.75	9.75
Maximum (unloading) pressure, Full-Feature	psig	141	141	141	141	141
Nominal working pressure	bar(e)	9.5	9.5	9.5	9.5	9.5
Nominal working pressure	psig	138	138	138	138	138
Pressure drop over dryer	bar(e)	0.15	0.15	0.15	0.15	0.25
Pressure drop over dryer	psig	2.18	2.18	2.18	2.18	3.62
Motor shaft speed	rpm	2840	2840	2840	2840	2940
Set-point, thermostatic valve	°C	71	71	71	71	71
Set-point, thermostatic valve	°F	160	160	160	160	160
Temperature of air leaving receiver (approx.), Pack	°C	33	33	33	33	33
Temperature of air leaving receiver (approx.), Pack	°F	91	91	91	91	91
Pressure dew-point, Full-Feature	°C	3	3	3	3	3
Pressure dew-point, Full-Feature	°F	37	37	37	37	37
Power input, Pack at maximum working pressure	kW	3.8	4.1	4.9	6.6	9.0
Power input, Pack at maximum working pressure	hp	5.1	5.5	6.57	8.85	12.27

Compressor type		GX 2	GX 3	GX 4	GX 5	GX 7
Power input, Full-Feature at maximum working pressure	kW	4.1	4.4	5.2	6.9	9.25
Power input, Full-Feature at maximum working pressure	hp	5.5	5.9	6.97	9.25	12.61
Power consumption, dryer at full load	kW	0.23	0.23	0.23	0.23	0.26
Power consumption, dryer at full load	hp	0.31	0.31	0.31	0.31	0.35
Power consumption, dryer at no load	kW	0.16	0.16	0.16	0.16	0.19
Power consumption, dryer at no load	hp	0.21	0.21	0.21	0.21	0.25
Refrigerant type		R134a	R134a	R134a	R134a	R134a
Total amount, refrigerant	kg	0.17	0.17	0.17	0.17	0.29
Total amount, refrigerant	lb	0.37	0.37	0.37	0.37	0.64
Oil capacity	l	2.5	2.5	2.5	2.5	2.5
Oil capacity	US gal	0.66	0.66	0.66	0.66	0.66
Sound pressure level floor-mounted units (according to ISO 2151 (2004))	dB(A)	61	61	62	64	66

60 Hz 10 bar

Compressor type		GX 2	GX 4	GX 5	GX 7
Frequency	Hz	60	60	60	60
Maximum (unloading) pressure, Pack	bar(e)	10	10	10	10
Maximum (unloading) pressure, Pack	psig	145	145	145	145
Maximum (unloading) pressure, Full-Feature	bar(e)	9.75	9.75	9.75	9.75
Maximum (unloading) pressure, Full-Feature	psig	141	141	141	141
Nominal working pressure	bar(e)	9.5	9.5	9.5	9.5
Nominal working pressure	psig	138	138	138	138

Compressor type		GX 2	GX 4	GX 5	GX 7
Pressure drop over dryer	bar(e)	0.15	0.15	0.15	0.25
Pressure drop over dryer	psig	2.18	2.18	2.18	3.62
Motor shaft speed	rpm	3495	3490	3495	3525
Set-point, thermostatic valve	°C	71	71	71	71
Set-point, thermostatic valve	°F	160	160	160	160
Temperature of air leaving receiver (approx.), Pack	°C	33	33	33	33
Temperature of air leaving receiver (approx.), Pack	°F	91	91	91	91
Pressure dew-point, Full-Feature	°C	3	3	3	3
Pressure dew-point, Full-Feature	°F	37	37	37	37
Power input, Pack at maximum working pressure	kW	3.7	4.7	6.3	9.0
Power input, Pack at maximum working pressure	hp	4.96	6.3	8.45	12.27
Power input, Full-Feature at maximum working pressure	kW	4	5	6.6	9.25
Power input, Full-Feature at maximum working pressure	hp	5.36	6.71	8.85	12.61
Power consumption, dryer at full load	kW	0.24	0.24	0.24	0.32
Power consumption, dryer at full load	hp	0.33	0.33	0.33	0.44
Power consumption, dryer at no load	kW	0.17	0.17	0.17	0.22
Power consumption, dryer at no load	hp	0.23	0.23	0.23	0.30
Refrigerant type		R134a	R134a	R134a	R134a
Total amount, refrigerant	kg	0.17	0.17	0.17	0.29
Total amount, refrigerant	lb	0.37	0.37	0.37	0.64
Oil capacity	l	2.5	2.5	2.5	2.5
Oil capacity	US gal	0.66	0.66	0.66	0.66
Sound pressure level floor-mounted units (according to ISO 2151 (2004))	dB(A)	61	62	64	66

9 Instructions for use

Oil separator vessel

1	The vessel can contain pressurised air. This can be potentially dangerous if the equipment is misused.
2	This vessel must only be used as a compressed air/oil separator tank and must be operated within the limits specified on the data plate.
3	No alterations must be made to this vessel by welding, drilling or other mechanical methods without the written permission of the manufacturer.
4	The pressure and temperature of this vessel must be clearly indicated.
5	The safety valve must correspond with pressure surges of 1.1 times the maximum allowable operating pressure. It should guarantee that the pressure will not permanently exceed the maximum allowable operating pressure of the vessel.
6	Use only oil as specified by the manufacturer.
7	In case of misuse of the units (frequent operation with too low oil temperature or long interval of shut down), a certain amount of condensate can gather in the oil separator vessel which must be properly drained. To do so, disconnect the unit from the power line, wait till it is cooled down and depressurised and drain the water by the oil drain valve, positioned at the bottom side of the oil separator vessel. Local legislation may require an periodic inspection.

Air receiver (on tank-mounted units)

1	Corrosion must be prevented: depending on the conditions of use, condensate may accumulate inside the tank and must be drained every day. This may be done manually by opening the drain valve, or by means of the automatic drain, if fitted to the tank. Nevertheless, a weekly check of correct functioning of the automatic valve is needed. This has to be done by opening the manual drain valve and check for condensate. Verify that no rust obstructions affect the drain system.
2	Yearly service inspection of the air receiver is needed, as internal corrosion can reduce the steel wall thickness with the consequent risk of bursting. Local rules need to be respected, if applicable. The use of the air receiver is forbidden once the wall thickness reaches the minimum value as indicated in the service manual of the air receiver (part of the documentation delivered with the unit).
3	Lifetime of the air receiver mainly depends on the working environment. Installing the compressor in a dirty and corrosive environment is not allowed, as this can reduce the vessel lifetime dramatically.
4	Do not anchor the vessel or attached components directly to the ground or fixed structures. Fit the pressure vessel with vibration dampers to avoid possible fatigue failure caused by vibration of the vessel during use.
5	Use the vessel within the pressure and temperature limits stated on the nameplate and the testing report.
6	No alterations must be made to this vessel by welding, drilling or other mechanical methods.

10 Guidelines for inspection

Guidelines

On the Declaration of Conformity / Declaration by the Manufacturer, the harmonised and/or other standards that have been used for the design are shown and/or referred to.

The Declaration of Conformity / Declaration by the Manufacturer is part of the documentation that is supplied with this compressor.

Local legal requirements and/or use outside the limits and/or conditions as specified by the manufacturer may require other inspection periods as mentioned below.

11 Pressure equipment directives

Components subject to 97/23/EC Pressure Equipment Directive

Components subject to 97/23/EC Pressure Equipment Directive greater than or equal to category II:
safety valves.

See the spare parts book for part numbers.

Overall rating

The compressors conform to PED smaller than category I.

12 Declaration of conformity

EC DECLARATION OF CONFORMITY

- 1
 2 We, ⁽¹⁾ declare under our sole responsibility, that the product
 3 Machine name
 4 Machine type
 5 Serial number
- 6 Which falls under the provisions of article 12.2 of the EC Directive 2006/42/EC on the approximation of the laws of the Member States relating to machinery, is in conformity with the relevant Essential Health and Safety Requirements of this directive.

The machinery complies also with the requirements of the following directives and their amendments as indicated.

7	Directive on the approximation of laws of the Member States relating to	Harmonized and/or Technical Standards used	Att'mnt
a.	Pressure equipment	97/23/EC	
b.	Machinery safety	2006/42/EC	EN ISO 12100 – 1 EN ISO 12100 – 2 EN 1012 – 1
c.	Simple pressure vessel	2009/105/EC	
d.	Electromagnetic compatibility	2004/108/EC	EN 61000-6-2 EN 61000-6-4
e.	Low voltage equipment	2006/95/EC	EN 60034 EN 60204-1 EN 60439
f.	Outdoor noise emission	2000/14/EC	
g.	Equipment and protective systems in potentially explosive atmospheres	94/9/EC	
h.	Medical devices General	93/42/EEC	EN ISO 13845 EN ISO 14971 EN 737-3
i.			

8.a The harmonized and the technical standards used are identified in the attachments hereafter

8.b (Product company) is authorized to compile the technical file.

9		Conformity of the specification to the directives	Conformity of the product to the specification and by implication to the directives
10			

11	Issued by	Product engineering	Manufacturing
12			
13			
14	Name		

15 Signature

16 Date

81679D

Typical example of a Declaration of Conformity document

(1): Contact address:

Atlas Copco Airpower n.v.

P.O. Box 100

B-2610 Wilrijk (Antwerp)

Belgium



In order to be First in Mind—First in Choice® for all your quality compressed air needs, Atlas Copco delivers the products and services that help to increase your business' efficiency and profitability.

Atlas Copco's pursuit of innovation never ceases, driven by our need for reliability and efficiency. Always working with you, we are committed to providing you the customized quality air solution that is the driving force behind your business.

