



GV-Eye Mobile App.

- 1. Specifications** 2
- 2. Supported GV-IP Devices and Software**..... 3
 - 2.1 Supported Products for Connection 3
 - 2.2 Supported Products for Recording 5
 - 2.3 Supported Products for Assigning NAS Storage Path..... 5
- 3. Installing GV-Eye** 6
- 4. Main Page** 7
- 5. GV-Relay QR Code** 9
 - 5.1 Setting up GV-Relay Account 10
 - 5.2 Connecting via GV-Relay QR Code 12
 - 5.3 Managing GV-Relay Account 16
 - 5.3.1 Purchasing Relay Data** 16
 - 5.3.2 Sharing Relay Data** 17
- 6. Manual & Automatic Connection for GV-IP Devices and Software** 18
 - 6.1 Required Configurations on GV-Software before Connecting..... 19
 - 6.1.1 Connection Settings on GV-VMS** 20
 - 6.1.2 Connection Settings on GV-DVR / NVR** 21
 - 6.1.3 Connection Settings on GV-Recording Server / Video Gateway** 22
 - 6.2 Configuring Windows Firewall for Communication..... 23
 - 6.3 Port Forwarding 25
 - 6.4 Manual Connection..... 26
 - 6.5 Automatic Connection 28
- 7. Group Management** 31
- 8. Live View** 33
- 9. Playing Back Recordings** 38
 - 9.1 Accessing the Recorded Files 38
 - 9.2 Playback Display 40
- 10. Edge Settings**..... 43
 - 10.1 Changing IP Address 44
 - 10.2 Changing Device Name..... 45
 - 10.3 Assigning Storage Path 46
 - 10.4 Monitoring HDD Storage..... 48
- 11. System Settings** 49
- 12. Defining the User Privilege of GV-VMS for GV-Eye**..... 51



GV-Eye



Using GV-Eye, you can access GV-IP devices and software from your mobile devices, to watch live views, play back recordings, trigger outputs and take snapshots.

IMPORTANT: Starting from GV-Eye V2.7, users can connect to GV-VMS (V17.4 / V18.1 or later), GV-DVR/NVR (V8.8.0 or later) and GV-Recording Server/Video Gateway (V2.0.0 or later) via GV-Relay QR-code. This is a paid service that results in connecting to GV-SNVR via QR-code scan to be charged as well.

1. Specifications

General

Supported OS	iOS 8 ~ 13; Android 5.0 ~ 10
Codec	MPEG4, MJPEG, H.264 and H.265
Resolutions	Up to 12 MP (4000 x 3000)
Functions	360° Mode, Live View, PIP (Picture-in-picture), Fisheye Dewarping, PTZ Control & Preset, Remote Playback, I/O Output trigger, Snapshot, 2-Way Audio, Stream Switching, Device Search, Hardware Decoding, Add via QR code
Languages	English, Japanese, Traditional Chinese

Default Port Settings

Below is a list of default port for GeoVision services that are used for remote connection.

Service	Connection Port	Playback Port
GV-IP devices (VSS Port)	10000	5552 80
GV-Recording Server / Video Gateway Server	11000	5552
GV-Mobile Server	55000	N/A
GV-VMS	56000	5552
GV-DVR/NVR	56000	5552
GV-SNVR	10000	80



Note:

1. Hardware decoding is only supported by devices using Android 4.1 or later and containing a GPU (graphic processing unit).
 2. Access is only allowed for **Admin** users when connecting to GV-IP devices.
 3. By default, GV-Eye connects to stream 2 of any GV-IP device, which is in H.264 codec and CIF resolution.
 4. IP devices connected to GV-Recording Server/Video Gateway (V2.0.0 or later), GV-VMS (V17.4 / V18.1 or later), GV-DVR/NVR (V8.8.0 or later) and GV-SNVR0411 / 0811 / 0812 / 1600 / 1611 can be remotely accessed by GV-Eye via GV-Relay QR code, see 5. *GV-Relay QR Code*.
-

2. Supported GV-IP Devices and Software

GV-Eye is compatible with the following GV-IP devices and video management software.

2.1 Supported Products for Connection

GV-IP Camera

- **All GV-IP Cameras** (with the latest firmware)

GV-Compact DVR

- **GV-Compact DVR V2** (firmware V1.10 or later)
- **GV-LX4C3 Series 4-Ch Compact DVR V3** (firmware V1.04 or later)
- **GV-LX8C Series 8-Ch Compact DVR V3** (firmware V1.02 or later)

GV-Video Server

- **GV-VS04A** (firmware V1.06 or later)
- **GV-VS11** (firmware V1.03 or later)
- **GV-VS12** (firmware V1.07 or later)
- **GV-VS14** (firmware V1.01 or later)
- **GV-VS2400 / 2420**
- **GV-VS2401**
- **GV-VS2800 / 2820**
- **GV-VS21600**



Surveillance System

- **GV-SNVR0400F**
- **GV-SNVR0411** (firmware V2.00 or later)
- **GV-SNVR0811**
- **GV-SNVR0812**
- **GV-SNVR1600**
- **GV-SNVR1611**

Note:

1. To upgrade your GV-IP devices to the latest firmware, please visit our [website](#).
 2. For GV-SNVR0400F, playback is not supported using GV-Eye. For GV-SNVR1600, playback is only supported by firmware V1.2 or later.
-

Video Management Software

- **GV-Mobile Server** (V1.3 or later)
- **GV-Recording Server** (V1.22 or later)
- **GV-Video Gateway** (V1.22 or later)
- **GV-VMS** (V14.10 or later)
- **GV-DVR/NVR** (V8.6 or later)



2.2 Supported Products for Recording

You can enable or disable recording for the following products and versions remotely through GV-Eye.

GV-IP Camera

- **All GV-IP Cameras** (with the latest firmware)

Note: When connected to GV-Eye, recording is not supported by the following models:

1. GV-ABL / ADR / AVD / EBD / QSD / TBL / TDR / TVD series
 2. GV-FD8700-FR / GV-VD8700 / GV-VR360
 3. GV-SD2322-IR / GV-SD2722-IR / GV-SD3732-IR
-

GV-Video Server

- **GV-VS11** (firmware V1.03 or later)
- **GV-VS12** (firmware V1.07 or later)
- **GV-VS14** (firmware V1.01 or later)
- **GV-VS2400 / 2420**
- **GV-VS2401**
- **GV-VS2800 / 2820**
- **GV-VS21600**

Video Management Software

- **GV-VMS** (V15.10 or later)

2.3 Supported Products for Assigning NAS Storage Path

GV-Eye can only assign NAS storage path for the following supported products and versions.

GV-IP Camera

- **GV-Target IP Cameras** (firmware V1.02 or later)
- **Other GV-IP Cameras** (firmware V3.0 or later)



3. Installing GV-Eye

You can download GV-Eye from the **App Store** or **Google Play** and install the application.

Upon first-time startup, you will be directed to a dialog box to enable or disable **Demo Mode**. Select **Yes** to enable **Demo Mode** to be guided through the key features of GV-Eye. Select **No** to disable **Demo Mode** and the main page appears.

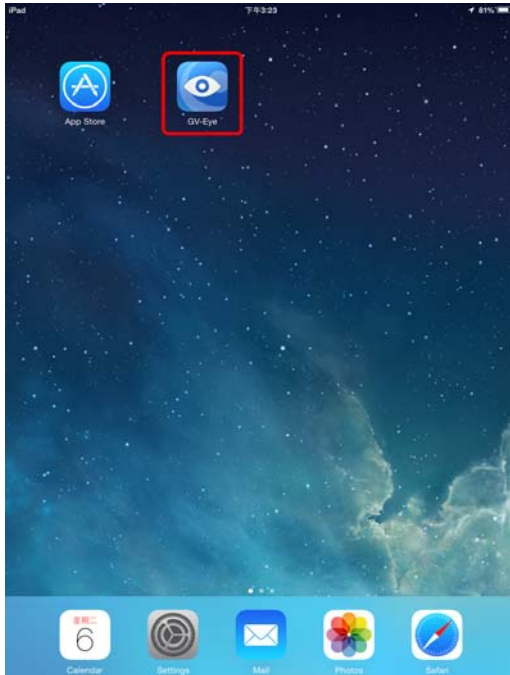

GV-Eye icon on iPad

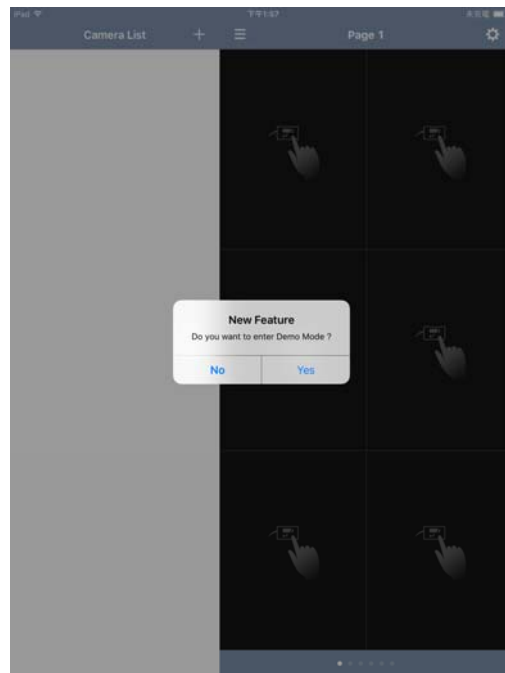

Dialog Box of Demo Mode on iPad



4. Main Page

The following main page is exemplified using an iPad.

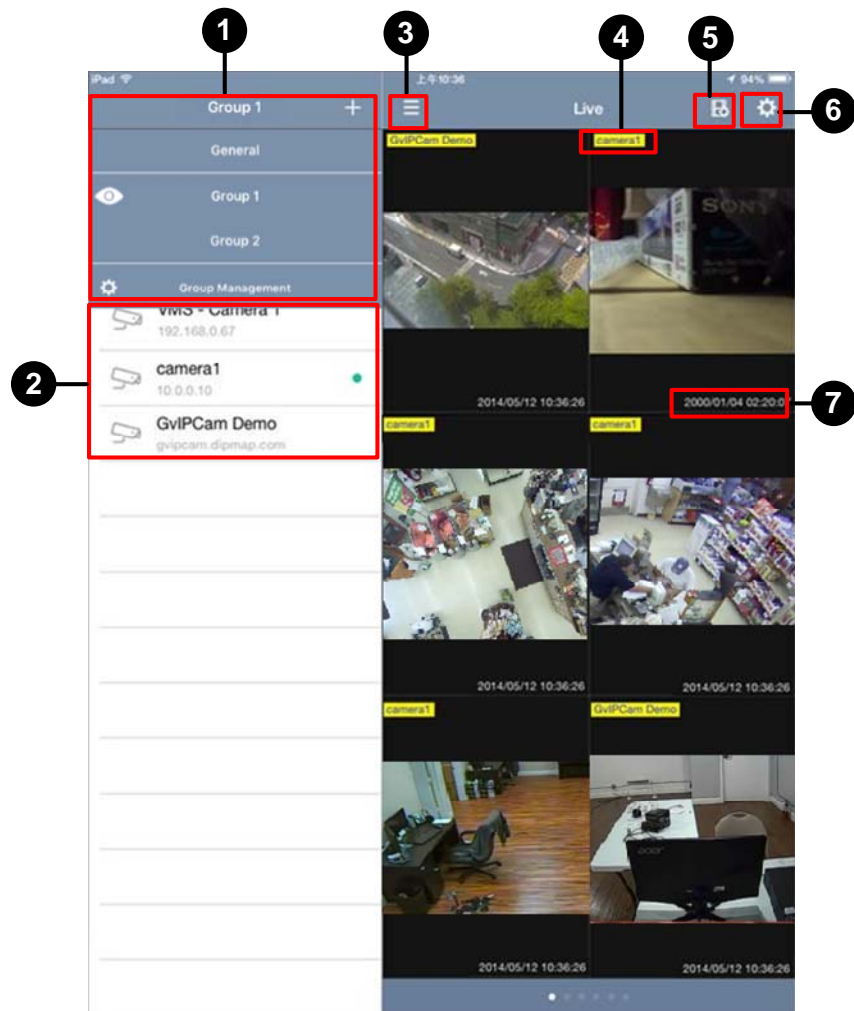

No.	Name	Function
1.	Group List	Manages groups for GV-IP devices. For details, see 7. <i>Group Management</i> .
2.	Camera List	Adds and removes connections to GV-IP devices and software. For details. Depending on the type of connection desired, see 5. <i>GV-Relay QR Code</i> and/or 6. <i>Manual & Automatic Connection for GV-IP Devices and Software</i> .
3.	Full Screen	<u>iPads and Android Tablets</u> : Opens and closes the Camera List. <u>iPhones, iPod Touch and Android Phones</u> : Opens the Camera List.
4.	Device Name	Displays the device name, which turns red during recording.



No.	Name	Function
5.	Edge Setting	Configures IP address and recording storage path of the device.
6.	Settings	Tap this button to access the GV-Eye settings. For details, see <i>11. System Settings</i> .
7.	Device Time	Displays the device time.



5. GV-Relay QR Code

GV-Eye can be connected to GV-IP devices and software under the same LAN, through the Internet or by scanning of the GV-Relay QR code. The following sections focus on connecting by GV-Relay QR-code, which avoids the precondition of configuring for Windows Firewall and port forwarding. To do this, the binding of a GV-Relay account is required, see *5.1 Setting up GV-Relay Account*.

Note:

1. This function is only supported by GV-DVR/NVR (V8.8.0 or later), GV-VMS (V17.4 / V18.1 or later), GV-Recording Server/Video Gateway (V2.0.0 or later), GV-SNVR0411 (firmware V2.00 or later), GV-SNVR0811 (firmware V2.30 or later), GV-SNVR1600 (firmware V1.20 or later), GV-SNVR0812 and GV-SNVR1611.
 2. The GV-Relay data is a paid service and if users don't want to purchase data after the free quota given is used up, they may connect manually, see *6. Manual & Automatic Connection for GV-IP Devices and Software*.
 3. All images streamed via GV-Relay QR-code connection shall consume the data within the GV-Relay account according to their resolutions and fps, and you won't be able to access such streams once the data is used up.
 4. To use this function, the GV-Software must be connected to the Internet.
 5. To connect manually or detect for GV-IP devices under the same LAN, see *6 Manual & Automatic Connection for GV-IP Devices and Software*.
-



5.1 Setting up GV-Relay Account

For connecting by the QR-code scan, you must first set up a GV-Relay account. To do this, tap  on the main page to access the settings page and tap **Add a binding account** under **Account Management**. The following page appears.

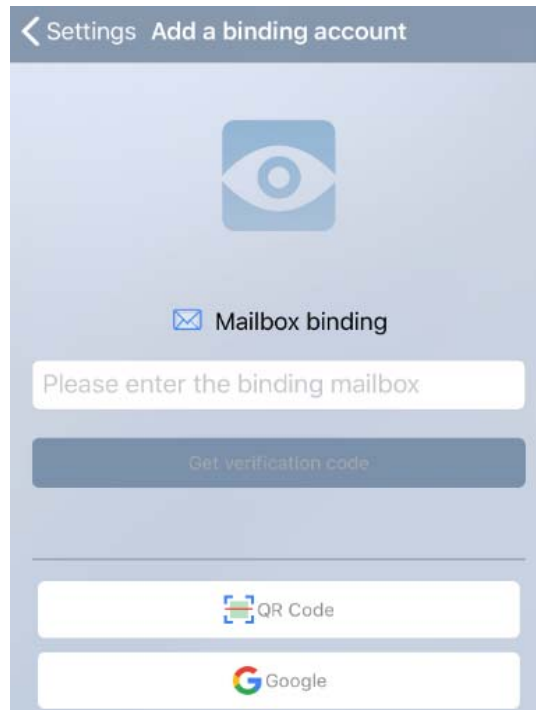

1. Type a valid e-mail address under **Mailbox binding** to use it as your GV-Relay account.
 - A. Tap **Get verification Code**. The **Email verification** page appears.
 - B. Upon receiving of the verification code, enter the 4-digit code within its validity period of 10 minutes, as illustrated below and tap **verification**.

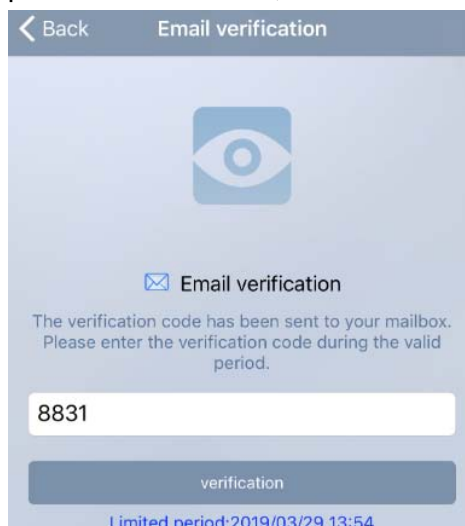



2. Alternatively, tap **Google** to log into your Google account.
3. Once successfully bound, the e-mail or Google account is used as your GV-Relay account and tracks the amount of data available, for viewing images through relay.

Note: All GV-Relay accounts are given 10.00 GB of free data every month and additional data can be purchased as desired, see [5.3.1 Purchasing Relay Data](#).

To connect to GV-Software by scanning GV-Relay QR code, see [5.2 Connecting via GV-Relay QR Code](#).

To manage your GV-Relay account, see [5.3 Managing GV-Relay Account](#).



5.2 Connecting via GV-Relay QR Code

You can connect to GV-Software by scanning its GV-Relay QR code. To do this, follow the steps below.

Note:

1. For connecting by the QR-code scan, you must first set up a GV-Relay account, see [5.1 Setting up GV-Relay Account](#).
 2. To use this function, the GV-Software must be connected to the Internet.
 3. For the list of GV-Software supported, refer to Note 1 in [5. GV-Relay QR Code](#)
-

1. On the GV-Software, go to its corresponding service/settings page, as described below:
 - A. For GV-VMS, click **Toolbar > Network > Mobile Server > QR Code**, select **Enable** and click **Start**. By default, GV-Relay uses the port value of 443.



Note: When port 443 has been used by other servers, such as for WebCam SSL or RTSP, select port 9443 for GV-Relay connection instead.



- B. For GV-DVR/NVR, click **Network > Webcam Server > QR Code**, select **Enable** and click **OK** for the changes to take effect. Note that the **Mobile Server (Webcam Server > Mobile)** must be enabled first. Once enabled, close the dialog box and scan the QR code within **WebCam**, which can be accessed via *Windows notification*.

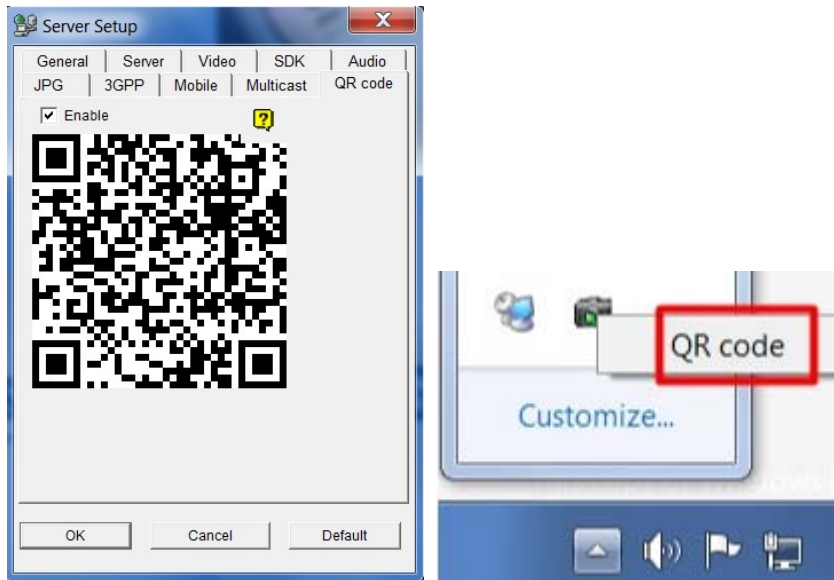



- C. For GV-Recording Server/Video Gateway, click **Server > Video Gateway**, select **Yes** to enable **Video Relay** and click **Save** for the changes to take effect.

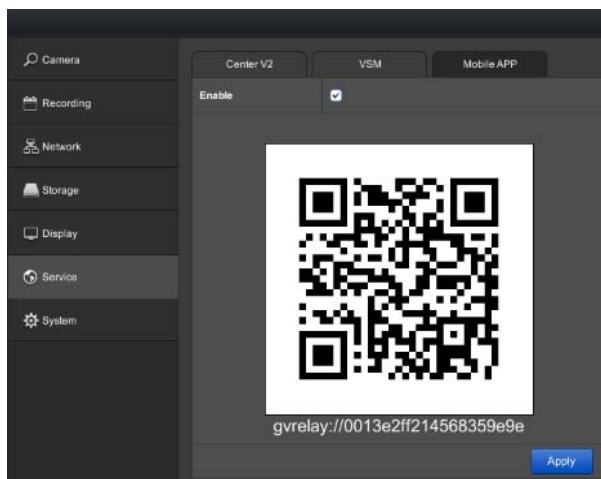

- D. For GV-SNVR, click **Setting > Service > Mobile APP**, select **Enable** and click **Apply** for the changes to take effect.





2. Tap **Add**  on the Camera / Group List page (No. 3, 4 Main Page) to access the **Add Device** page.
3. Tap **QR-code scan** . The QR code reader appears.

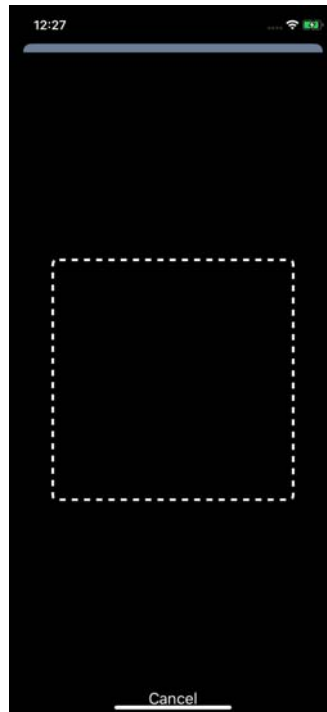

4. Hold your device over the QR code on the GV-Software to the point where the QR code is clearly visible. When the scanning is successful, the following page appears. Type a desired **Name** and the login Username and Password of the GV-Software and tap **Get Information**.



5. All IP devices from the GV-Software are displayed. Select the devices you want to be imported to GV-Eye and click **Save**.

Add Device Save

Device Info

Name: GV-VMS

IP Address: 72804ace-65ec-4cdf-89f8...

WebPort: 80

Port: 10000

Username: 1

Password:

Get Information

-
- GV-VMS - Camera 1
- GV-VMS - Camera 2
- GV-VMS - Camera 3
- GV-VMS - Camera 4
- GV-VMS - Camera 5
- GV-VMS - Camera 6

All of the selected IP devices are added to the GV-Eye under a Host Group.



5.3 Managing GV-Relay Account

When you are logged into your GV-Relay account, the following Account Management page appears.

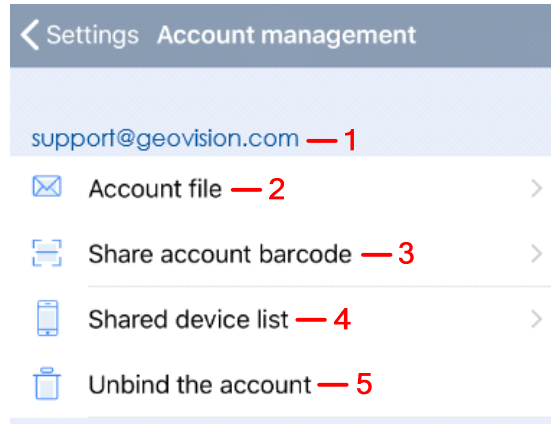

No.	Name	Function
1.	Account name	Displays the GV-Relay account currently logged in.
2.	Account file	Tap to view the amount of data on the GV-Relay account and/or purchase data. See 5.3.1 <i>Purchasing Relay Data</i> .
3.	Share account barcode	Tap to display a QR code for sharing the account's data to other mobile devices. See 5.3.2 <i>Sharing Relay Data</i> .
4.	Shared device list	Tap to display all mobile device(s) using the data of the GV-Relay account logged in. See 5.3.2 <i>Sharing Relay Data</i> .
5.	Unbind the account	Tap to log off the GV-Relay account.

5.3.1 Purchasing Relay Data

To purchase data, tap **Account file** (No. 2, 5.3 *Managing GV-Relay Account*) and **Shopping cart** . The Purchase page appears.



Tap the **Shopping cart**  next to the amount of data you want to purchase.





5.3.2 Sharing Relay Data

The data of a GV-Relay account can be shared to other mobile devices for GV-Relay streaming on those devices. To share the data from device A to device B, follow the steps below:

1. On device A, tap **Share account barcode** (No. 3, 5.3 *Managing GV-Relay Account*) The Share account QR code, with its validity period, appears.



2. On device B, start GV-Eye and tap  > **Add a binding account** and tap the **QR Code** button  QR Code .
3. Scan the QR code from Step 1 using device B. Once successfully scanned, the data from device A is shared to device B.

All images streamed by GV-Relay connection on both device A and B will consume the data from device A.

Removing Shared Device(s)

To remove a shared device, tap **Shared device list** (No. 4, 5.3 *Managing GV-Relay Account*) and select the account you want to remove.



6. Manual & Automatic Connection for GV-IP Devices and Software

GV-Eye can be connected to GV-IP devices and software under the same LAN or through the Internet.

Note:

1. To connect by the GV-Relay QR code, see 5. *GV-Relay QR Code*.
2. If the GV-IP Devices and/or software to which you want to connect isn't behind a Windows Firewall or router, the related settings may be skipped.

Refer to the following sections according to the type of connection needed:

For GV-Software / SNVR

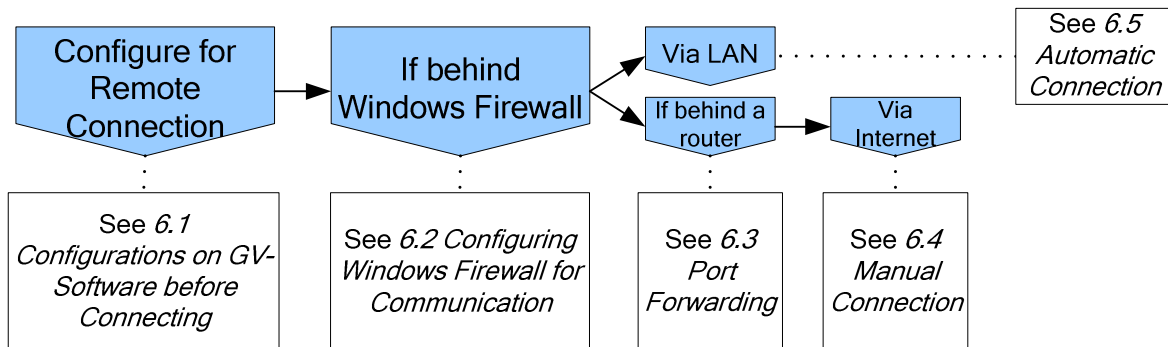

For GV-IP Devices

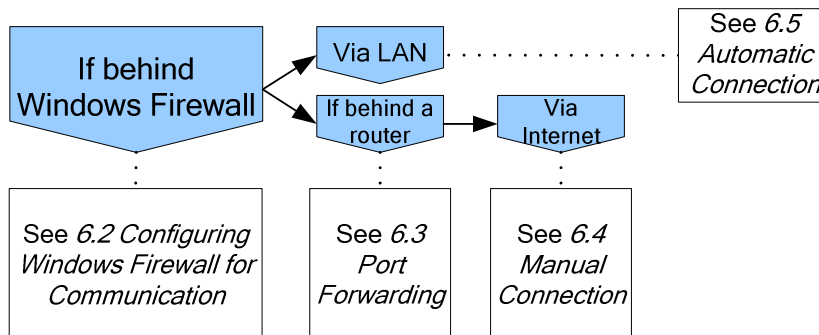



6.1 Required Configurations on GV-Software before Connecting

For GV-Software to be accessible by GV-Eye, the related services and the corresponding port(s) must first be enabled. Refer to the following sections depending on the type of GV-Software in which you want to connect:



- For GV-VMS, see [6.1.1 Connection Settings on GV-VMS](#)
- For GV-DVR / NVR, see [6.1.2 Connection Settings on GV-DVR / NVR](#)
- For GV-Recording Server / Video Gateway, see [6.1.3 Connection Settings on GV-Recording Server / Video Gateway](#)

Note:



1. There are no required configurations for GV-SNVR to be accessible by GV-Eye. If the GV-SNVR is behind a router, see [6.3 Port Forwarding](#) and [6.4 Manual Connection](#), respectively, for connecting to GV-Eye through the Internet. Otherwise see [6.5 Automatic Connection](#) for connecting to GV-Eye within the same LAN.
 2. While there are also no required configurations for GV-Mobile Server, if it is behind an active Windows Firewall, make sure its mobile service is allowed for communication. See [6.2 Configuring Windows Firewall for Communication](#).
-

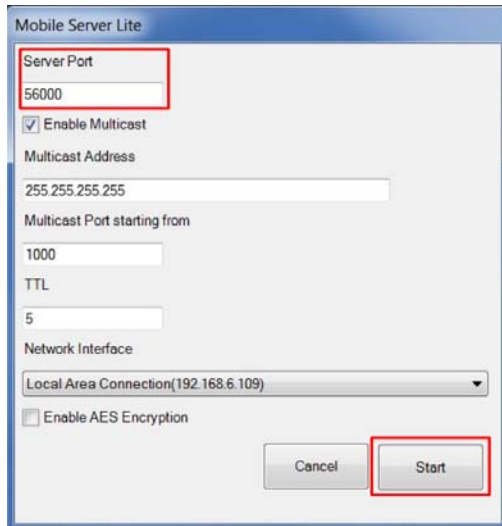

6.1.1 Connection Settings on GV-VMS

1. On your GV-VMS, click **Home**  > **Toolbar**  > **Network**  > **Mobile Service**. The Mobile Server Lite dialog box appears.
2. Keep the default **Server Port** of 56000 or modify if necessary and click **Start**.



3. Click **Home**  > **Toolbar**  > **Network**  to make sure **Mobile Service** is enabled, and optionally click **Control Center Server** and enable **Remote ViewLog Service** to allow remote playback through GV-Eye.

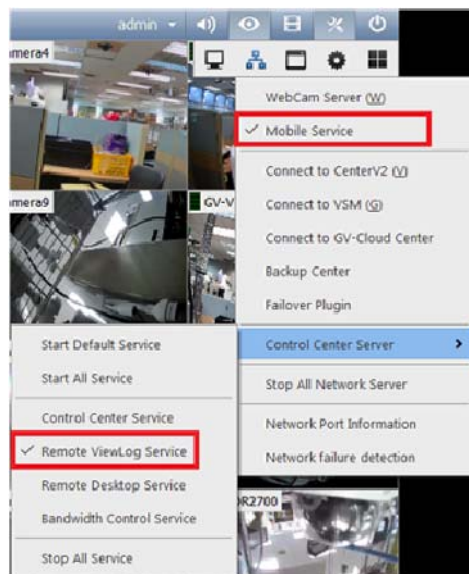

IMPORTANT: After the abovementioned settings are set, if the PC has an active Windows Firewall, the related services must also be enabled on the Windows Firewall for GV-VMS to be accessible by GV-Eye. See [6.2 Configuring Windows Firewall for Communication](#).



6.1.2 Connection Settings on GV-DVR / NVR

1. On the main screen of GV-DVR / NVR, click **Network**  and select **Webcam Server**. The Server Setup dialog box appears.
2. In the **Mobile** tab, select the upper-left checkbox to enable mobile service and its corresponding ports. Keep the default **Stream Port** of 56000 or modify if necessary.

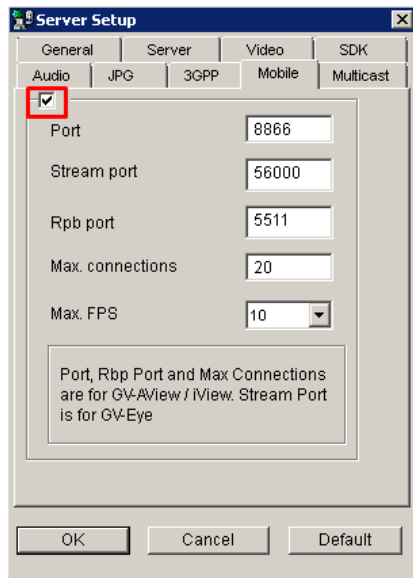

3. Optionally select **Run ViewLog Server** in the **General** tab to allow remote playback through GV-Eye.

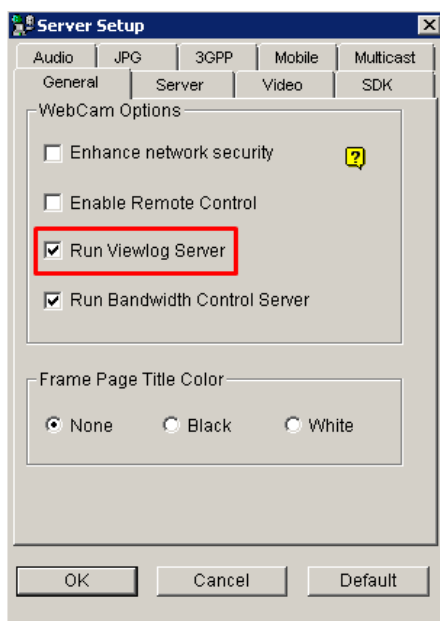



4. Click **OK**. The GV-DVR / NVR can now be added to GV-Eye.

IMPORTANT: After the abovementioned settings are set, if the PC has an active Windows Firewall, the related services must also be enabled on the Windows Firewall for GV-DVR / NVR to be accessible by GV-Eye. See [6.2 Configuring Windows Firewall for Communication](#).





6.1.3 Connection Settings on GV-Recording Server / Video Gateway

For GV-Recording Server / Video Gateway to be accessible by GV-Eye, its Recording Server and Video Gateway services must first be enabled. Note that these two services are enabled by default.

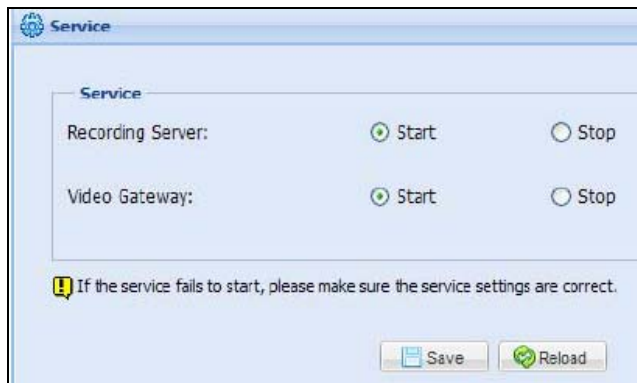
1. On the main screen of GV-Recording Server / Video Gateway, click **Server**  > **Service** . This dialog box appears.



2. Make sure **Start** is selected for both **Recording Server** and **Video Gateway** and click **Save**.
3. Optionally click **Server**  > **Video Gateway**  to change the **Connect Port**, otherwise keep its default value of **11000**.

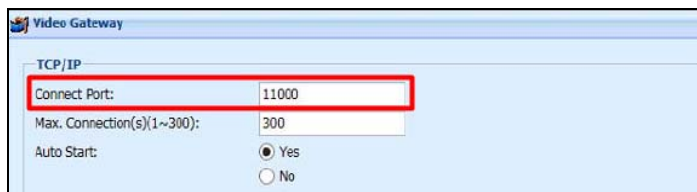

4. Click **Save**. The GV-Recording Server / Video Gateway can now be added to GV-Eye.

IMPORTANT: After the abovementioned settings are set, if the PC has an active Windows Firewall, the related services must also be enabled on the Windows Firewall for GV-Recording / Video Gateway to be accessible by GV-Eye. See [6.2 Configuring Windows Firewall for Communication](#).



6.2 Configuring Windows Firewall for Communication

For GV-Software installed on a PC with active Windows Firewall to be accessible by GV-Eye, the related services/programs must first be enabled:

1. Open **Control Panel** from the Windows Start menu, click **System and Security** > **Windows Firewall** and click **Allow a program or feature through Windows Firewall**. The Allowed Programs dialog box appears.



2. On the Allowed Programs list, select to allow the related services/programs depending on the type of GV-Software to which you want to access.

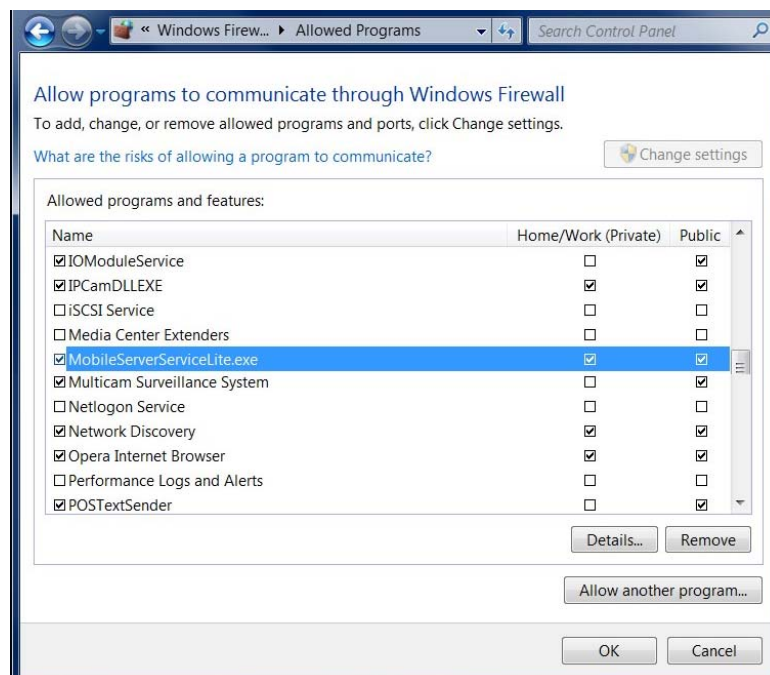

- a. For GV-VMS / DVR / NVR, allow **GeoRSWLite.exe**, **MobileServerServiceLite.exe** and **ViewLog Server** for both private and public networks.
- b. For GV-Recording Server / Video Gateway, allow **GeoRecordingServer.exe** and **ViewLog Server** for both private and public networks.
- c. For GV-Mobile Server, allow **GeoRSWLite.exe** and **MobileServerServiceLite.exe** for both private and public networks.



3. Click **OK**. The GV-Software can now be communicated through Windows Firewall.

Note:

1. If any one of the above programs cannot be found within the list, click **Allow another program... > Browse** and:
 - a. For GV-VMS / DVR / NVR, locate *GeoRSWLite*, *MobileServerServiceLite* and *Visvr* from the GV-VMS / DVR / NVR's directory.
 - b. For GV-Recording Server / Video Gateway, locate *GeoRecordingServer* and *Visvr* from the GV-Recording Server / Video Gateway's directory.
 - c. For GV-Mobile Server, locate *GeoRSW* and *MobileServerServiceLite* from the GV-Mobile Server's directory.

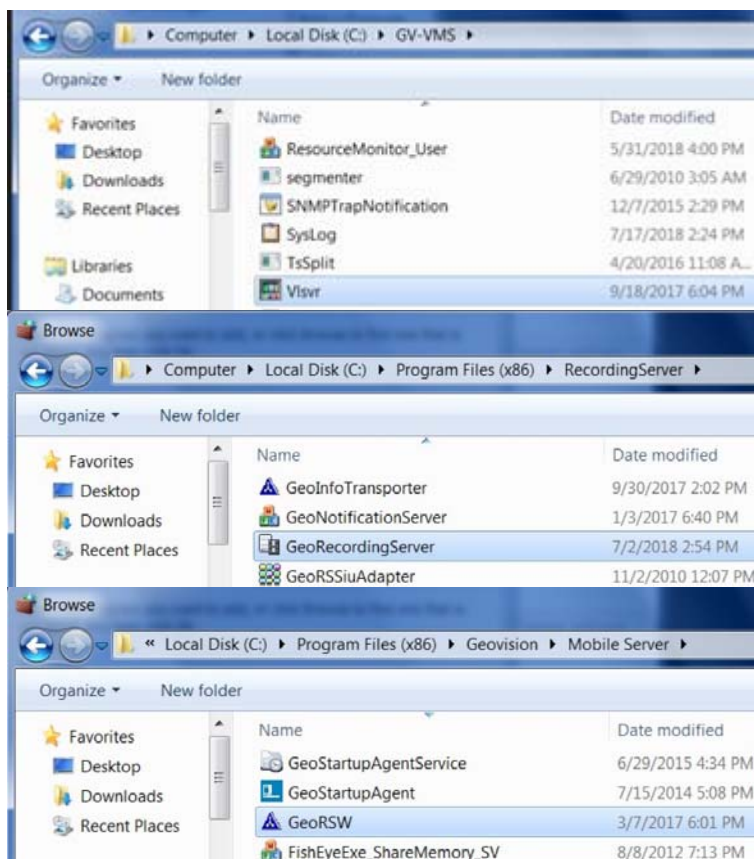

2. If the GV-Software is behind a router, see [6.3 Port Forwarding](#) and [6.4 Manual Connection](#), respectively, for connecting to GV-Eye through the Internet. Otherwise see [6.5 Automatic Connection](#) for connecting to GV-Eye within the same LAN.



6.3 Port Forwarding

If the GV-IP devices and/or software to which you are trying to connect are behind a router, you need to configure for port forwarding.

IMPORTANT: Prior to port forwarding, first make sure you have a public IP accessible through the Internet. This can be done by one of the following:

1. Register for a *static public IP address* from your Internet Service Provider (ISP).
2. Assign a *domain name* to your dynamic public IP address through the router's DDNS settings. Consult your router manufacturer for details.

1. For port forwarding depending on the brand and model of your router, click [here](#).
2. Make sure the ports mapped coincide with the GV-IP devices and software to which you want to connect:

	Default Connection Port	Default Playback Port
GV-IP devices (VSS Port)	10000	5552 80
GV-Recording Server / Video Gateway Server	11000	5552
GV-Mobile Server	55000	N/A
GV-VMS	56000	5552
GV-DVR/NVR	56000	5552
GV-SNVR	10000	80

3. After Port Forwarding is set, look for the GV-IP devices' and/or software's public IP address by typing "what is my ip" in a Web browser. Your Public IPv4 IP address is displayed within *WhatIsMYIP.com*.

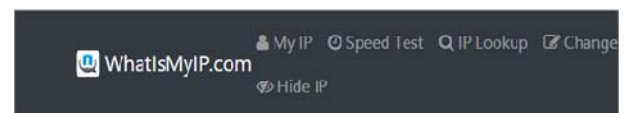
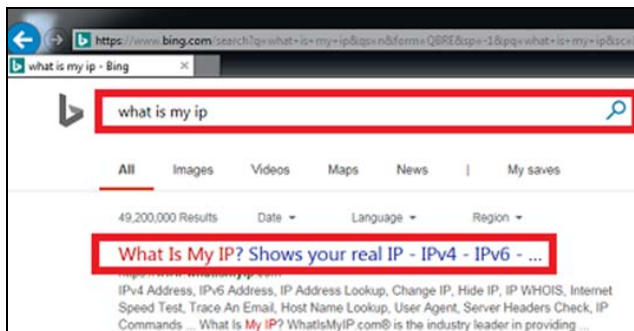



6.4 Manual Connection

1. Tap the **GV-Eye** icon  on the desktop of your mobile device. This page appears.

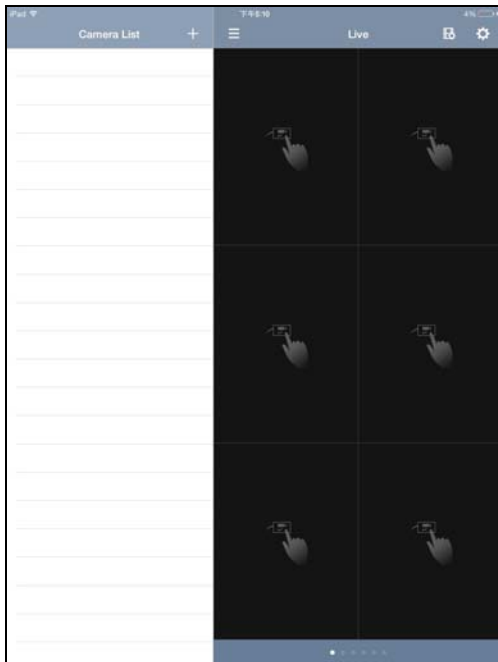

2. Tap the **Add** button . This page appears.

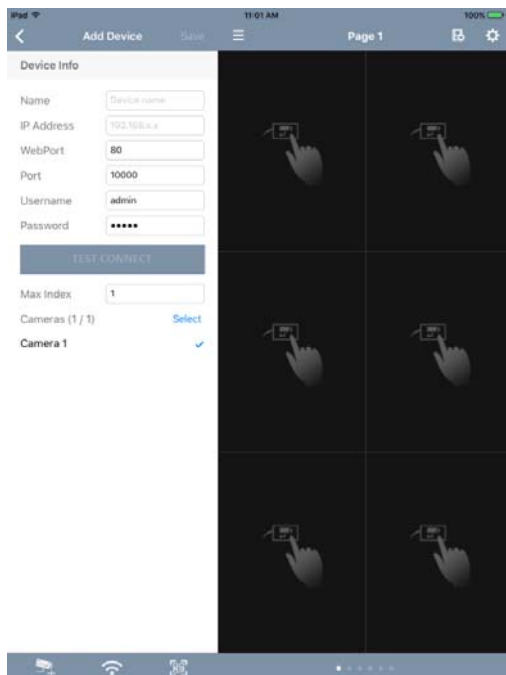



- On the Add Device page, enter the IP address, port number, username and password of the GV-IP device or software and enter a name.



- Type the local / public IP address or the domain name of the GV-IP device / software to which you want to connect, for within the LAN or through the Internet. For the public IP address, see *Step 3, 6.3 Port Forwarding*.
- Only modify the Web Port of 80, which is the default web port for all GV-IP device / software, when the corresponding web port on the device / software to which you want to connect has been changed.
- Type one of the below port values as Port, depending on the GV-IP device / software to which you want to connect.

GV-IP devices (VSS Port)	10000
GV-Recording Server / Video Gateway Server	11000
GV-Mobile Server	55000
GV-VMS	56000
GV-DVR/NVR	56000
GV-SNVR	10000

- Type the login Username and Password of the GV-IP device / software to which you want to connect.
- Tap **Test Connect**. The total number of cameras and each installed GV-IP Cameras are displayed.
 - By default, all the installed cameras are selected. To change this setting, deselect the cameras by tapping the check marks next to the cameras, or tap **Select** to set the range of cameras to add.
 - Tap **Save** on the top-right corner. The selected cameras are added to Camera List.





6.5 Automatic Connection

For automatic connection, GV-IP devices and software must be within the same LAN as your GV-Eye. For connecting to GV-Software, the related settings on the respective software must first be configured, see *6.1 Required Configurations on GV-Software before Connecting*.

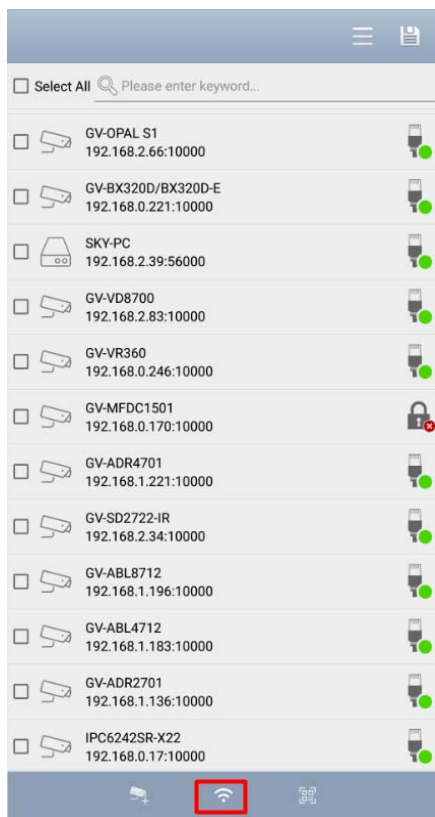
1. Follow Step 1 to 2 in *6.4 Manual Connection* to access the Add Device page.
2. Tap the **WiFi** icon  below to detect any GeoVision IP devices and software under the same LAN.



Icon	Description
	Logged in successfully
	Incorrect login – tap to type the login Username and Password for the device



3. Select the desired GV-IP devices and software and tap **Save** .

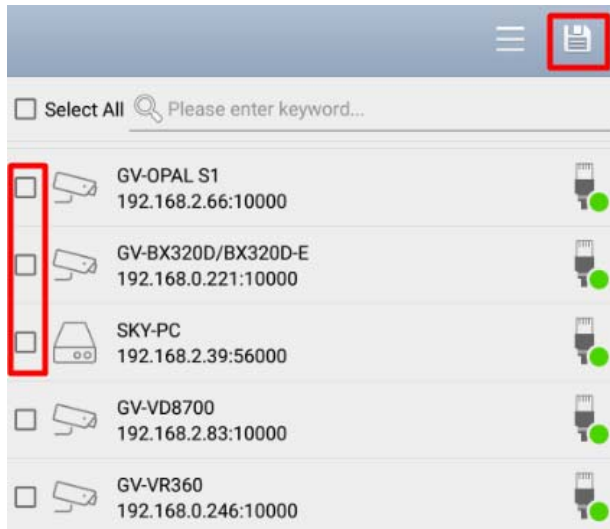

4. To display a camera live view, tap and drag the camera from the Camera List to the live view grid you want.

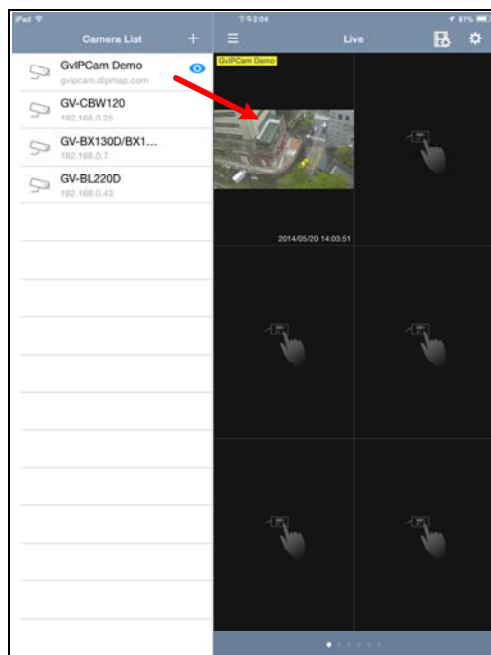



5. To disconnect a live view, tap and hold the live view and drag the live view into the trash can icon.

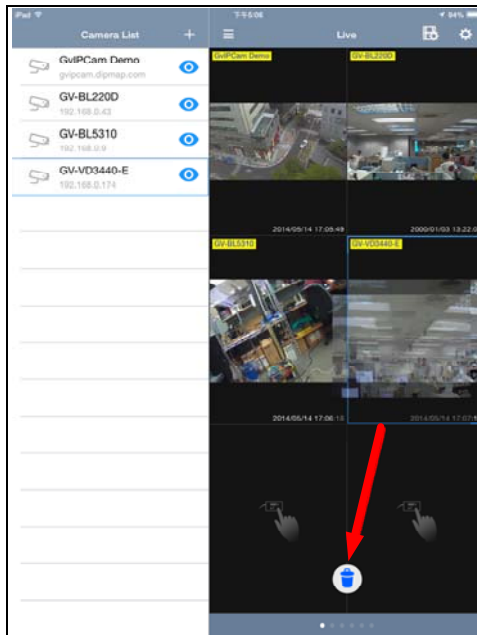

6. To remove an entry from the Camera List, glide the entry to the left and tap **Delete**.

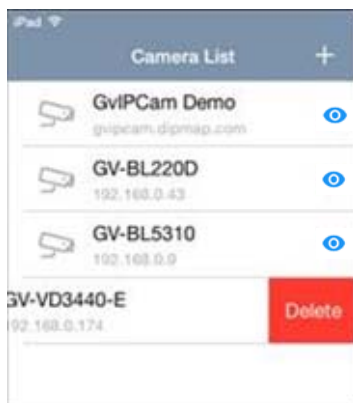

7. To change the device information, tap the entry from the Camera List to modify. The modified camera will be reconnected after you save the settings.



7. Group Management

Follow the steps below to create up to 100 different groups for your GV-IP devices.

1. In the Settings page (No. 6, 4. Main Page), tap **Group Management**.

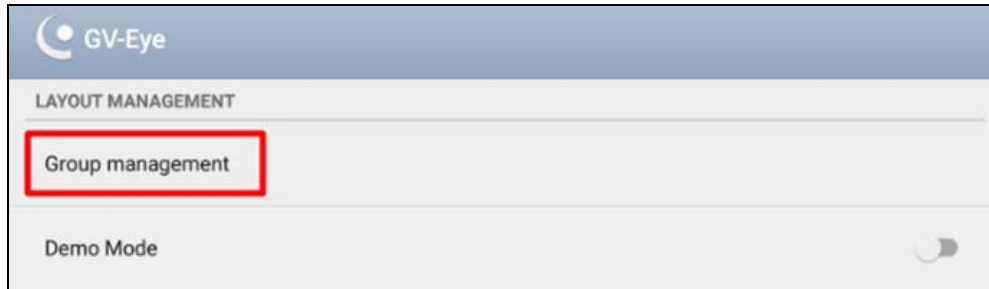

2. On the Group Management page, tap **Edit**, and tap the name field to name the group.

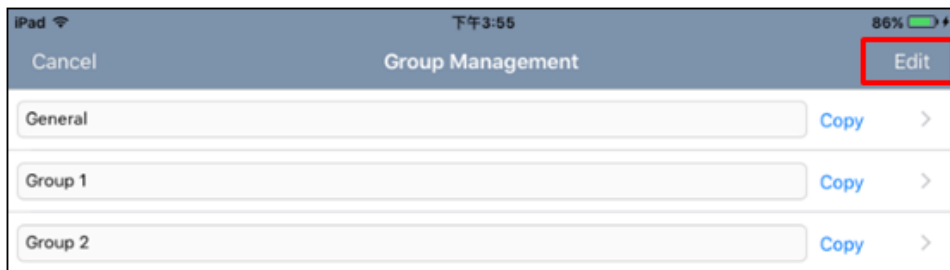

3. To choose layouts for each group, tap the > sign. There are 6 pages in total with each displaying up to 16 channels of live view.

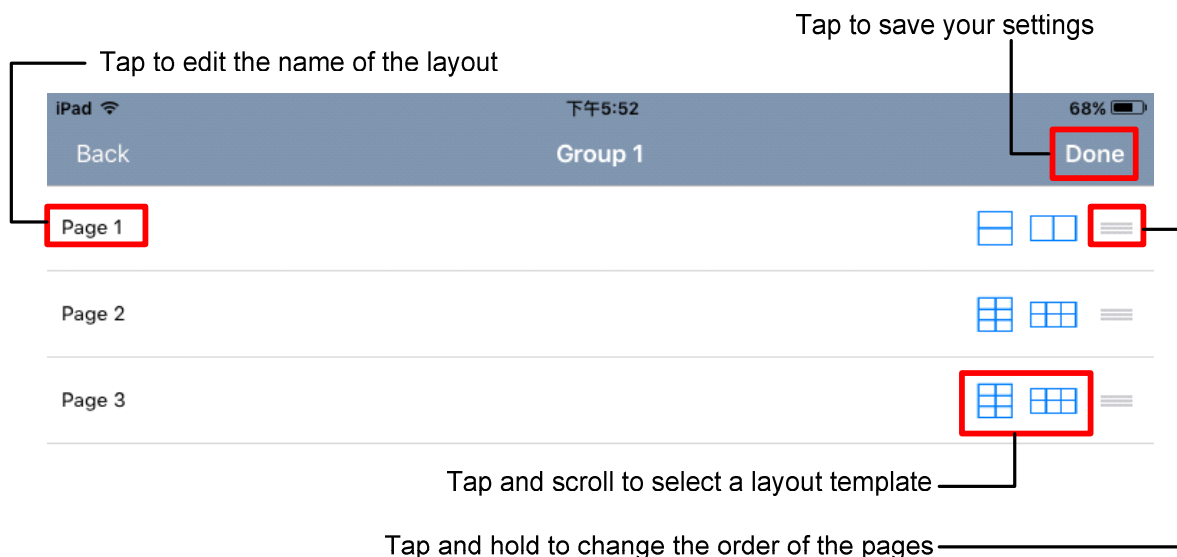



- Return to the main page and select a desired group for adding IP devices.

Click to display the drop-down list of the group menu

The screenshot displays the GeoVision mobile application interface. On the left, a drop-down menu is open, showing options: Group 1 (+), General, Group 1 (with an eye icon), Group 2, Group 1 (copy), and Group Management (with a gear icon). A red box highlights the 'Group 1' header in the background app view. The background app view shows a list of devices under 'Group 1': TEST-303-PC (192.168.2.224), GV-BL220D (192.168.0.43), GV-BL5310 (192.168.0.9), and GV-VD3440-E (192.168.0.174). To the right, a 2x2 grid of camera feeds is displayed. The top-left feed is labeled 'GvIPCam Demo' and shows an outdoor street view. The top-right feed is labeled 'GV-BL220D' and shows an indoor office view. The bottom-left feed is labeled 'GV-BL5310' and shows an indoor view of a room with shelves. The bottom-right feed is labeled 'GV-VD3440-E' and shows an indoor view of a room with a desk. Timestamps are visible at the bottom of the feeds: 2014/05/14 17:05:49, 2000/01/03 13:22:04, 2014/05/14 17:06:18, and 2014/05/14 17:07:15.





8. Live View

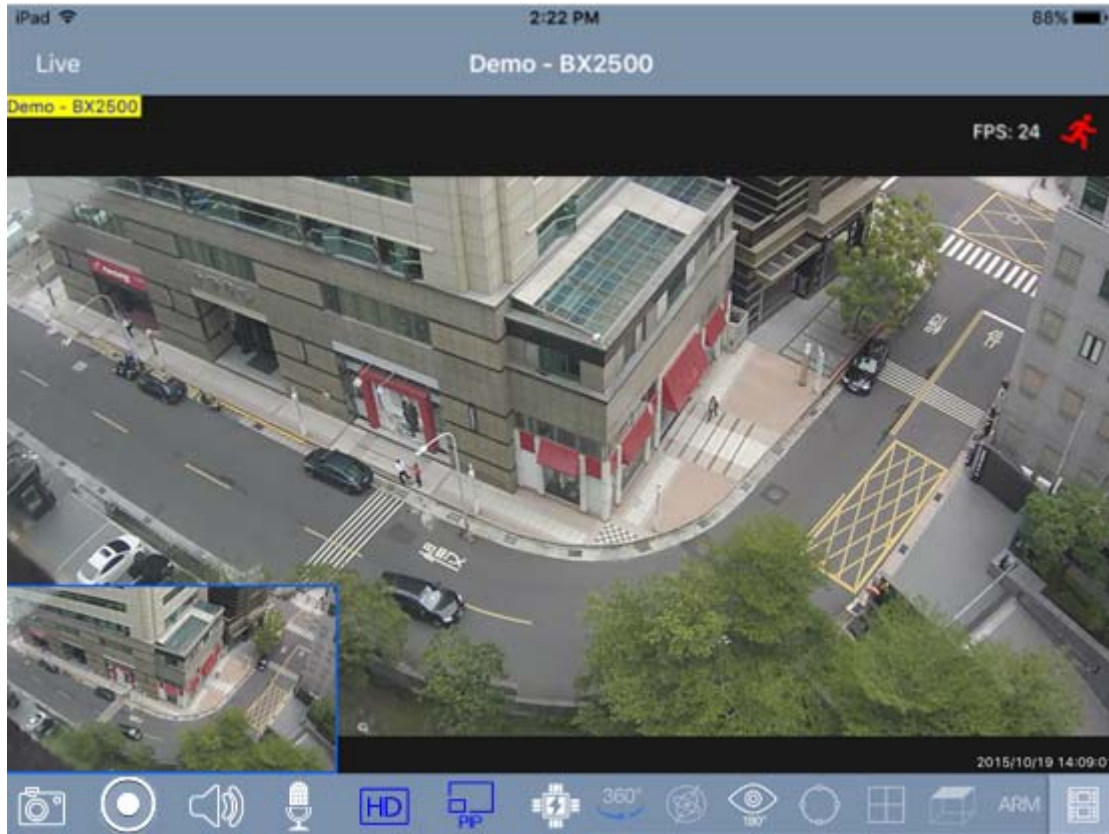













Tap any live view within the live view grid for a full-screen display as below.



You can access the following functions by tapping the corresponding icon. When the functions are enabled, the record icon glows red while the others glow blue.











Icon	Name	Function
	Snapshot	Snapshots the current live view and saves it to the photos or gallery folder of your mobile device.
	Camera Status	<p>Starts the recording. A colored camera name at the upper-left corner of the live view indicates the status of the camera.</p> <ul style="list-style-type: none"> • Yellow: successful connection between GV-IP devices and software • Green: starts monitoring • Red: starts recording













Icon	Name	Function
	Record	Tap the button to enable or disable recording to the connected camera.
	Speaker	Broadcasts sounds from the surveillance site. This function is enabled by default.
	Microphone	Speaks to the surveillance site. This function is enabled by default.
	Stream Switch	Switches the connected stream. By default, stream 2 (with lower resolution) is connected.
	PIP	Displays a picture-in-picture view which is a close-up view with its original view displayed in an inserted window. This function is enabled by default. On your mobile device, pinch to zoom the part of the live view you wish to examine. You can then glide on the screen to see the different parts of the close-up view.
	PTZ Panel	<p>Enables the PTZ control panel. You can control the camera view using the following:</p> <ul style="list-style-type: none"> : tap the arrow and drag toward the direction you wish to move the camera view  : zooms in and out  : focuses in and out : Moves the camera view to the home position : Moves the camera view to a predefined position by selecting a preset number
	Auto Focus	Automatically focuses the live view. This function is only accessible when the PTZ panel is enabled.
	I/O Trigger	Manually triggers the output and edit the output naming displayed on your mobile device.

Note: I/O Trigger does not support IP devices of the following models: [GV-ABL2702](#) / [ABL4712](#) / [ABL8712](#) / [AVD2700](#) / [AVD4710](#) / [AVD8710](#) / [EBD4711](#) / [EBD8711](#) / [SD2322-IR](#) / [SD2722-IR](#) / [SD3732-IR](#) / [TDR2700](#) / [TDR4700](#).



Icon	Name	Function
	360° Mode	<p>Displays the live view of a camera in panoramic view. You can swipe fingers on the screen in every direction to explore a 360° video. This function is disabled by default. Enables 360° View in the Settings page (see 11. System Settings), and the icon will be added on the live view.</p> <p>Note: The 360° Mode needs to work with GV-VR360 Camera.</p>
	VR Mode	<p>Switch the display mode of camera live view between 360° Mode  or VR head set view . This function is disabled by default. Taps 360° Mode  and the icon will be added on the live view.</p> <p>Note: The VR Mode needs to work with GV-VR360 Camera.</p>
	Gyroscopic Mode	<p>Allows the live image to rotate with the movement of a mobile device, such as a VR head set. This function is disabled by default. Taps 360° Mode , and the icon will be added on the live view.</p> <p>Note: The Gyroscopic Mode needs to work with GV-VR360 Camera.</p>
	Fisheye Dewarp	<p>Dewarps the fisheye live view and allows users to align the live view, select display mode and define the installation type. For details, see Image Alignment, Display Mode and Installation Type in this table.</p>
	Image Alignment	<p>Defines the size and center of the Fisheye view. Tap to enable this function and then enlarge, minimize and move the red circle. Tap this icon again to apply the setting.</p>
	Display Mode	<p>Defines the display mode of a GV-Fisheye Camera.</p> <ul style="list-style-type: none"> • Quad View: shows the live view in 4 PTZ views • 360-Degree View: shows 2 PTZ views and a 360° view • Single 180° view: shows one 180° view <p>Single View: shows one PTZ view</p>



Icon	Name	Function
	Installation Type	<p>Defines the installation type of a GV-Fisheye Camera. Tap the icon and select among:</p> <ul style="list-style-type: none">  ceiling mount  wall mount  ground mount
	Alarm Notification	<p>Enable the alarm notification to GV-Center V2 when events occur. This function is disabled by default. Enable ARM & E-mail in the Settings page (see <i>11. System Settings</i>), and the icon will be added on the live view.</p> <p>Note: The notification settings should be configured in advance on GV-IP Cameras.</p>
	E-mail Notification	<p>Enable the function of receiving alert notification through e-mails when events occur. This function is disabled by default. Enable ARM & E-mail in the Settings page (see <i>11. System Settings</i>), and the icon will be added on live view.</p> <p>Note: The notification settings should be configured in advance on GV-IP Cameras.</p>
	Playback	Plays back recordings. For details, see <i>9. Playing Back Recordings</i> later in this installation guide.
	Motion Detection	Indicates detected motions. The icon becomes red  when a motion is detected.
	Hardware Decode	Enables GPU decoding which lowers the CPU loading and increases the smoothness of live view.
	FPS	Indicates the number of frames per second, ranging from 0 to 30. The more frames per second, the smoother the motion appears.



Note:

1. The control of enabling or disabling recording  is only available for compatible products and versions. For details, see [2.2 Supported Products for Enabling Recording](#).
 2. PTZ Panel functions are fully or partially supported by the following GV-IP device:
 - GV-IP Speed Dome and GV-PTZ Camera: all functions supported
 - GV-PT Camera: all functions supported except zoom in/out
 - GV-IP Cameras that support remote focus/zoom adjustment: only support auto focus, focus in/out and zoom in/out.
 3. The microphone function is only supported by GV-IP Cameras and GV-Recording Server V1.3 or later.
-



9. Playing Back Recordings

9.1 Accessing the Recorded Files

Make sure the following functions are enabled ahead to allow remote access from the GV-Eye:

- GV-DVR / NVR / GV-VMS: enable **Remote ViewLog Service**. See 6.1 *Required Configurations on GV-Software before Connecting*.
- GV-IP Camera / GV-Video Server / GV-Compact DVR: enable **ViewLog Server**

Note:

1. If a router or firewall is installed with the remote servers and IP devices, ensure the corresponding playback port is open. For example, to play back the files from GV-DVR / NVR / VMS, open port 5552 on the router. For Windows Firewall settings see 6.2 *Configuring Windows Firewall for Communication*. For port forwarding and a full list of default port numbers, see 6.3 *Port Forwarding*.
2. To enable the Audio function for video playback, you must activate related Audio Settings.

GV-VMS: Setup > Audio Setting > enable **Rec Audio** and **Round-the-Clock Audio** options to enable Audio function in GV-Eye.

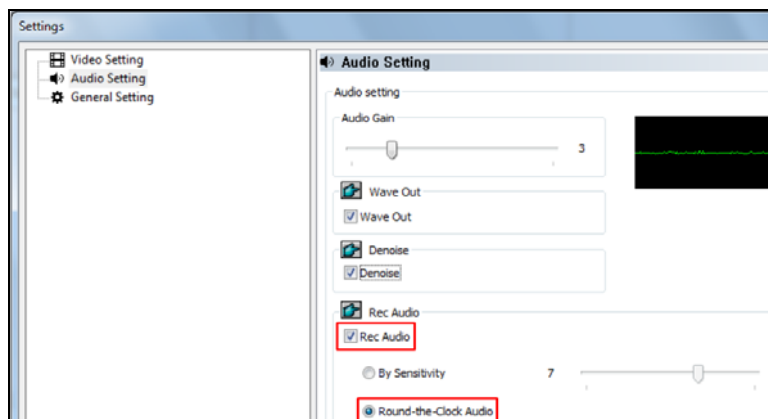



GV-DVR: Configure > A/V Settings > Audio Settings > enable **Rec Audio** and **Round-the-Clock Audio** options to enable Audio function in GV-Eye.

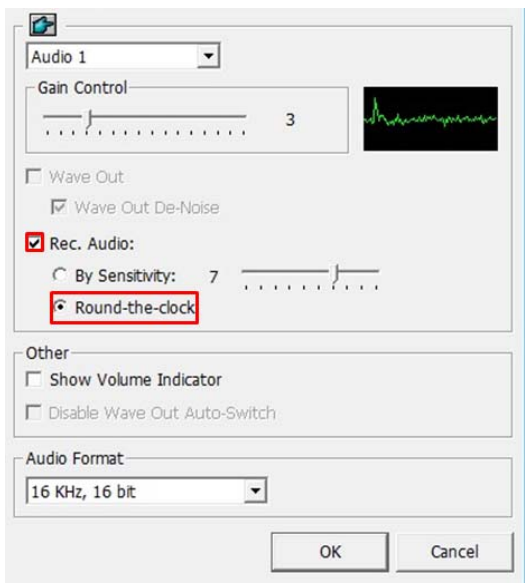



GV-SNVR: Camera Settings > enable **Audio** option to enable Audio function in GV-Eye.

3. Playback from the local storage, the recordings saved on the SD card, of GV-ABL2702 / ABL4712 / ABL8712 / AVD2700 / AVD4710 / AVD8710 / EBD4711 / EBD8711 / SD2322-IR / SD2722-IR / SD3732-IR / TDR2700 / TDR4700 is not supported.

1. From the live view page, tap . This page appears.



2. The recording files of the day are listed. Tap to select up to five videos. Tap  to start playing.
3. You can also tap the calendar icon  to view the recording status.

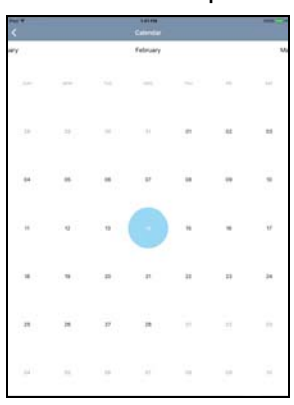





9.2 Playback Display









The full-screen display is as below.











You can access the following functions by tapping the corresponding icon. With the functions enabled, the icons glow blue.

Icon	Name	Function
	Export	Saves the .mp4 playback file when it is ready and share it with smartphone apps available on your mobile device.
	Snapshot	Snapshots the current playback and saves it to the photos or gallery folder of your mobile device.



Icon	Name	Function
	PIP	Displays a picture-in-picture view which is a close-up view with its original view displayed in an inserted window. This function is enabled by default. On your mobile device, pinch to zoom the part of the playback you wish to examine. You can then glide on the screen to see the different parts of the close-up view.
	Hide Control Bar	Hides the control bar on the playback window so that the users can get a full view of the playback display.
	Rotate	Rotates the playback display by 90° for each tap.
	Fisheye Dewarp	Dewarps the fisheye live view and allows users to align the playback scenes, select display mode and define the installation type. For details, see Image Alignment , Display Mode and Installation Type in this table.
	360° Mode	Displays the live view of a camera in panoramic view. You can swipe fingers on the screen in every direction to explore a 360° video. This function is disabled by default. Enables 360° View in the Settings page (see 11. System Settings), and the icon will be added on the live view. Note: The 360° Mode needs to work with GV-VR360 Camera.
	VR Mode	Switch the display mode of camera live view between 360° Mode  or VR head set view  . This function is disabled by default. Taps 360° Mode  and the icon will be added on the live view. Note: The VR Mode needs to work with GV-VR360 Camera.





Icon	Name	Function
	Gyroscopic Mode	<p>Allows the live image to rotate with the movement of a mobile device, such as a VR head set. This function is disabled by default. Taps 360° Mode , and the icon will be added on the live view.</p> <p>Note: The Gyroscopic Mode needs to work with GV-VR360 Camera.</p>
	Image Alignment	<p>Defines the size and center of the Fisheye view. Tap to enable this function and then enlarge, minimize and move the red circle. Tap this icon again to apply the setting.</p>
	Display Mode	<p>Defines the display mode of a GV-Fisheye Camera.</p> <ul style="list-style-type: none"> • Quad View: shows the live view in 4 PTZ views • 360-Degree View: shows 2 PTZ views and a 360° view • Single 180° view: shows one 180° view • Single View: shows one PTZ view
	Installation Type	<p>Defines the installation type of a GV-Fisheye Camera. Tap the icon and select among:</p> <ul style="list-style-type: none"> •  ceiling mount •  wall mount •  ground mount



10. Edge Settings

The Edge settings section allows you to configure the IP address, device name and storage path for GV-IP devices.

To access the settings, enable **Edge Tool** in the Settings page (see 11. System Settings), and the **Edge settings** button  will be added on the main page. Tap  and the Edge settings page appears.

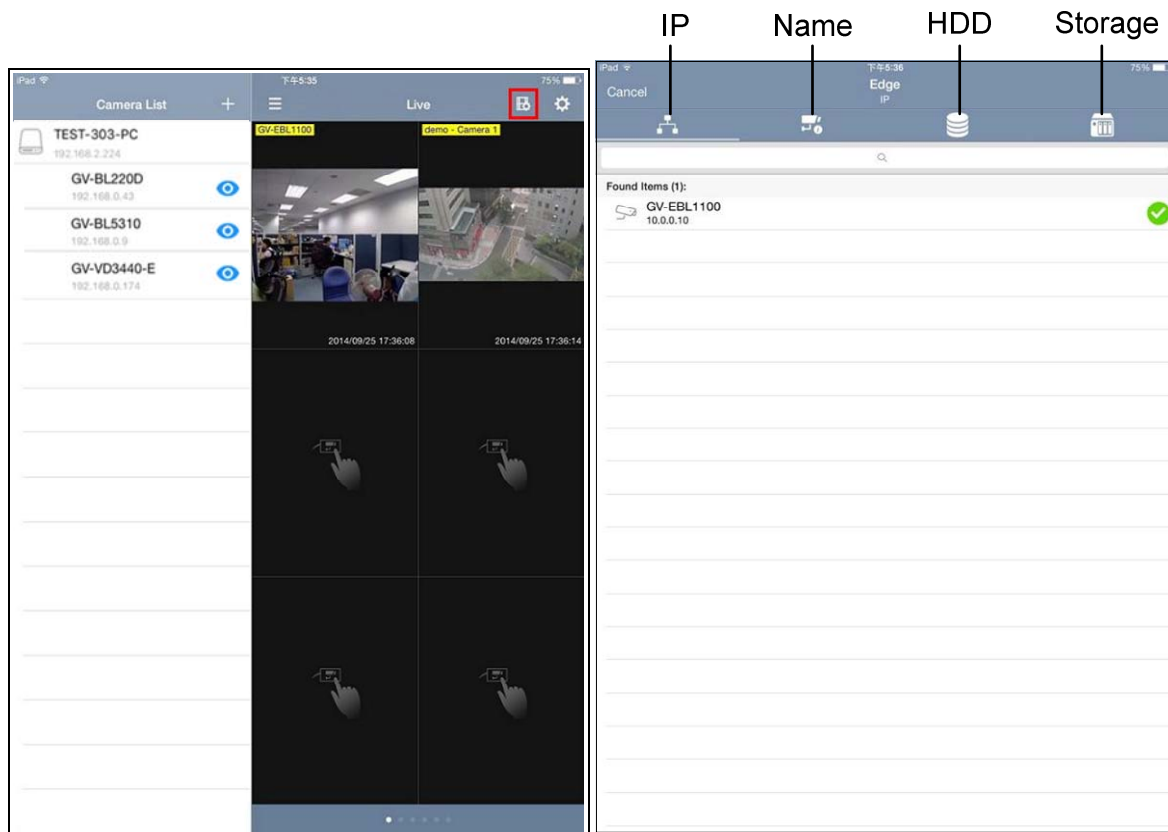

Main Page

Edge Settings Page

Note: For Android devices, tap  on the main page and tap **Edge Tool** to access the Edge settings.



10.1 Changing IP Address

To change the IP address of a GV-IP Device, follow the steps below.

Note: The function of changing IP address is only supported by compatible GV-IP Camera, GV-Video Server and GV-Compact DVR.

1. On the IP settings page, select the desired GV-IP Device. A green tick appears under camera name.
2. Tap **Next** at the upper-right corner. This page appears.



3. Type a new IP address and optionally tap the **Advanced** button to configure the Mask, Gateway and DNS settings.

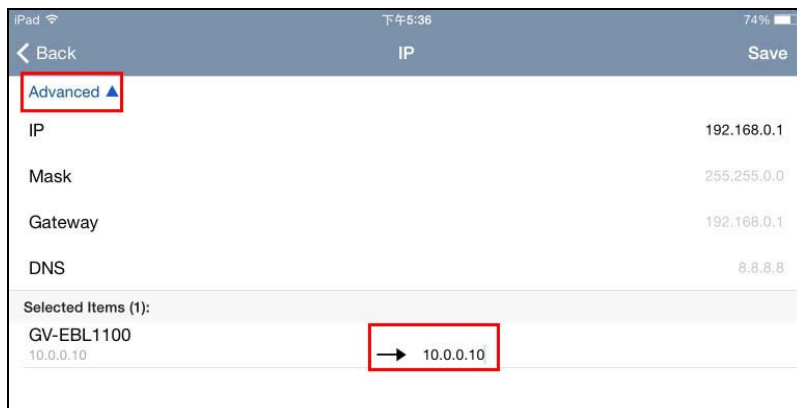

4. Tap **Save** to enable the settings.

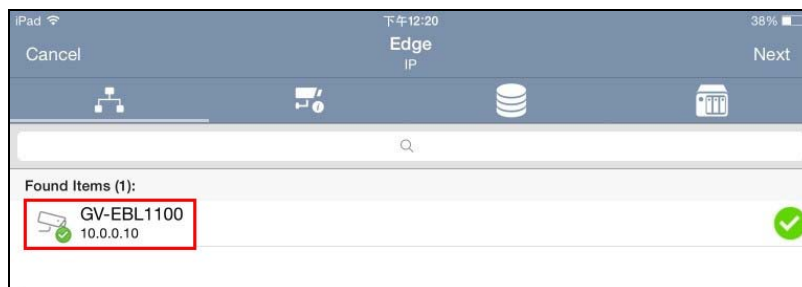



10.2 Changing Device Name

To change the device name of a GV-IP Device, follow the steps below.

Note: The function of changing device name is only supported by compatible GV-IP Camera, GV-Video Server and GV-Compact DVR.

1. On the Edge settings page, tap the **Name** button . The Name settings page appears.

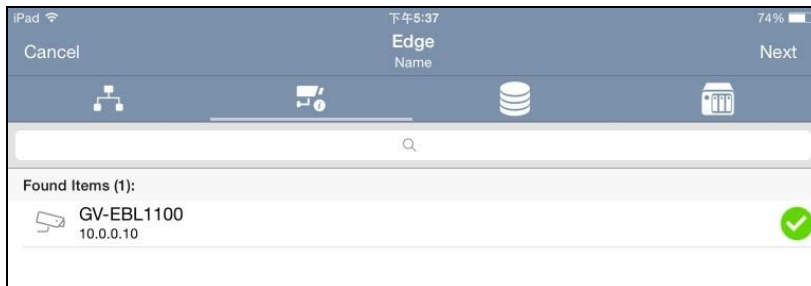

2. Select the desired GV-IP Device and tap **Next**. This page appears.



3. Type a new name for the device and tap **Save**.
4. On the Name settings page, pull to refresh. The device name is updated.

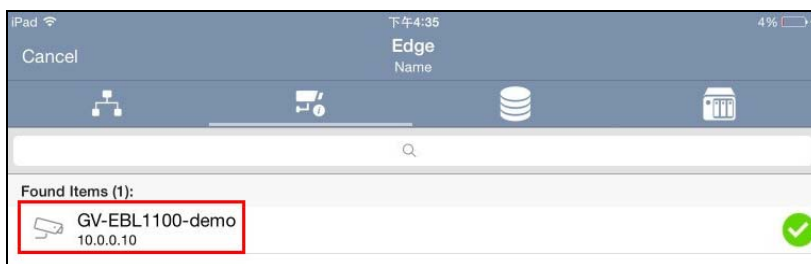



10.3 Assigning Storage Path

To assign the recording storage path on GV-NAS System for a GV-IP Camera, follow the steps below.

Note:

1. Make sure the camera stops recording before assigning storage path.
 2. This function is only supported by GV-IP Camera firmware V3.0 or later and GV-Target IP Camera firmware V1.02 or later.
 3. The Edge recording is only supported by GV-NAS Systems.
-

1. On the Edge settings page, tap the **HDD** button . The HDD settings page appears.

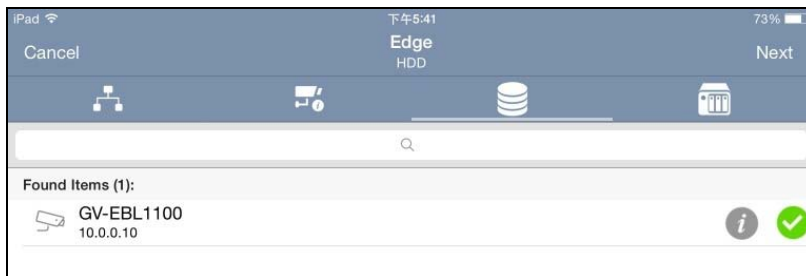

2. Select the desired camera and tap **Next**. This page appears.



3. Tap the **Edit** button  and select **Yes** in the pop-up dialog box to add a valid path.

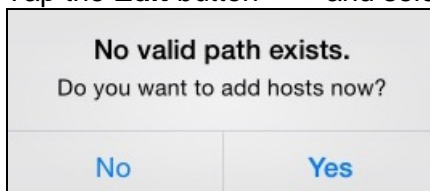



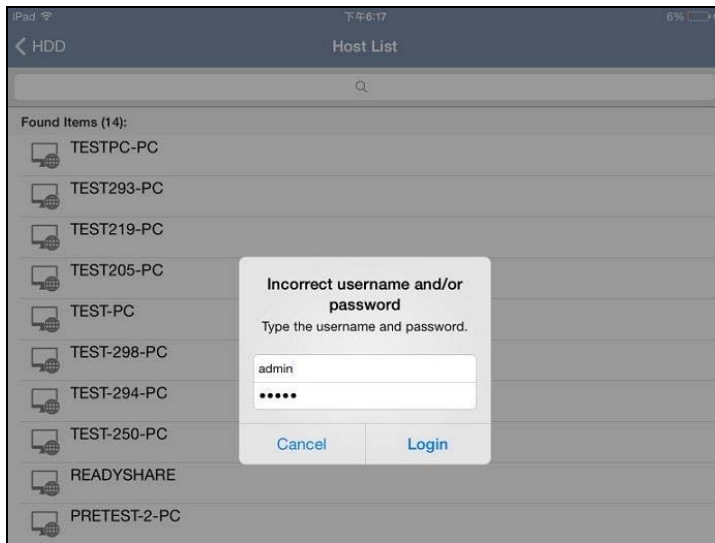

- In the pop-up Host List, select the desired host, type the username and password of the host and tap **Login**.

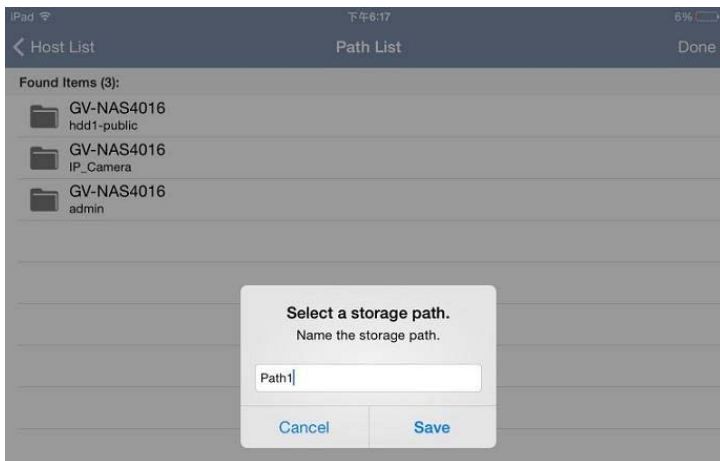

- In the pop-up Storage Path List, select the desired storage path, type a name and tap **Save**.



- To view the added storage path, on the Edge settings page, tap the **Storage** button . The added path is displayed.





10.4 Monitoring HDD Storage

To view the HDD storage status, tap the **Info** button  on the HDD settings page. The HDD Info page appears and displays the capacity.



Note:

1. This function is only supported by GV-IP Camera firmware V3.0 or later and GV-Target IP Camera firmware V1.02 or later.
 2. For the camera with its storage path being assigned on the GV-NAS System, the HDD Info page displays the NAS storage capacity; for the camera without storage path assigned, the HDD Info page displays the SD card storage capacity.
-



11. System Settings

To access GV-Eye settings, tap  on the main page. The settings page appears.

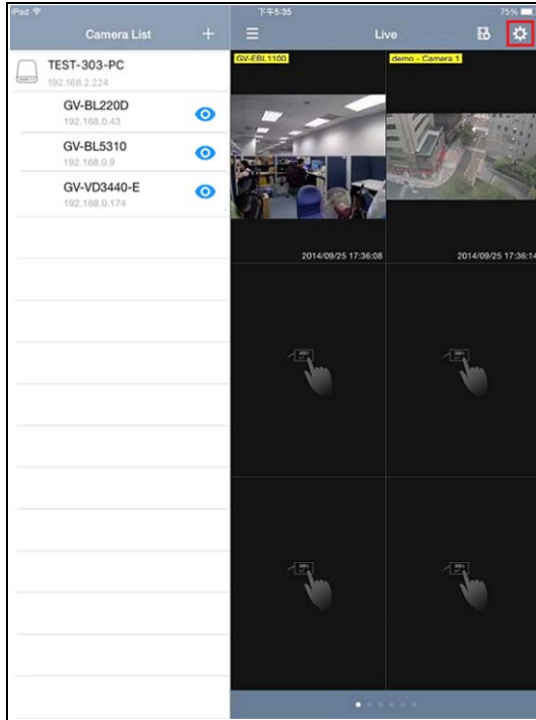

Main Page

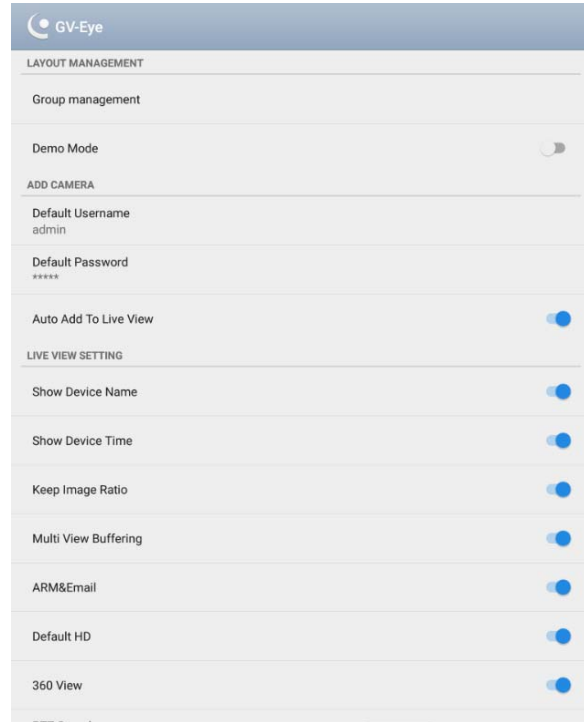

Settings Page

[LAYOUT MANAGEMENT]

- **Group Management:** Creates groups and arranges live view layouts. GV-Eye can receive up to 96 channels of live view from various GV-IP devices. Users can create up to 100 groups, and each group has 6 pages in total with each displaying up to 16 channels of live view. See 7. *Group Management* for details.
- **Demo Mode:** Displays 3 channels of live view for you to experience the features of GV-Eye.

Note: If you enable **Demo Mode**, your current connection of IP-devices and layout settings of live view will be temporarily closed. Instead, 3 demo channels and default layout will be displayed. To resume your previous settings, disable **Demo Mode**.

[ADD CAMERA]

- **Default Username:** Sets the default username when adding a new IP device to the Camera List. The default is **admin**.
- **Default Password:** Sets the default password when adding a new IP device to the Camera List. The default is **admin**.



- **Auto Add to Live View:** Automatically displays the added IP devices to live view. This function is disabled by default.

[LIVE VIEW SETTING]

- **Show Device Name:** Displays device name on live view.
- **Show Device Time:** Displays device time on live view.
- **Keep Image Ratio:** Displays the live view in proportion to the device's resolution.
- **Multi View Buffering:** Enhances the smoothness of live view with multiple divisions. Note this function is for Android devices only.
- **ARM & EMAIL:** Displays the alarm invocation and e-mail notification icons on live view.
- **Default HD:** Displays the live view in HD quality video. This function is enabled by default.
- **360 View:** Enables the panoramic view.
- **PTZ Speed:** Changes the PTZ speed. Speed 1 is the slowest and speed 5 the fastest.
- **Delete All Entries on Camera List:** Click to delete all the entries from the Camera List of all groups.
- **Export Camera List:** Export the current camera list as a QR code image to the internal storage of smartphone.
- **Import Camera List:** Scan the QR code containing the camera list, previously exported, to be loaded into GV-Eye.
- **Edge Tool:** Displays the edge settings icon on live view.

[ACCOUNT MANAGEMENT]

- **Add a binding account:** Logs into a GV-Relay Account, see 5. *GV-Relay QR Code*.

[PLAYBACK SETTING]

- **Audio:** Enable Audio function for video playback.
- **Hardware Acceleration:** Enable Hardware Acceleration function to increase the smoothness of playback. Note this function is enabled by default and for Android devices only.

[SYSTEM SETTING]

- **Disable Screen Off:** Turns off sleep mode of the mobile device when the GV-Eye is running.



12. Defining the User Privilege of GV-VMS for GV-Eye

In GV-VMS, you can alter user privileges to determine which user account can access Video, Audio, PTZ, Monitor Start/Stop and I/O Output Control from mobile app GV-Eye.

Note: The function is only supported by GV-VMS V16.10.3 or later.

To set up the user privilege:

1. Click **Home** , click the account ID, click **Password Setup**, and select **Local Account Edit** and select the **Web/Mobile** tab.
2. Select or deselect **Video**, **Audio**, **PTZ**, **Monitor Start/Stop** and **I/O Output Control** of specific cameras to allow or deny the user the function.

For instance, firstly, on the Local Account Edit dialog box of GV-VMS, you can deny User1 the access of PTZ. Then, when you log on GV-Eye with the ID and password of User1, you will see that User1 cannot access PTZ on GV-Eye.

